

Please check the examination details below before entering your candidate information

Candidate surname

Other names

Centre Number

Candidate Number

Pearson Edexcel International GCSE (9–1)

Tuesday 14 May 2024

Afternoon (Time: 1 hour 45 minutes)

Paper
reference

4HB1/01

Human Biology

UNIT: 4HB1

PAPER: 01

You must have:

Ruler

Candidates may use a calculator

Total Marks

Instructions

- Use **black** ink or ball-point pen.
- **Fill in the boxes** at the top of this page with your name, centre number and candidate number.
- Answer **all** questions.
- Answer the questions in the spaces provided
– *there may be more space than you need.*
- Show all the steps in any calculations and state the units.

Information

- The total mark for this paper is 90.
- The marks for **each** question are shown in brackets
– *use this as a guide as to how much time to spend on each question.*

Advice

- Read each question carefully before you start to answer it.
- Write your answers neatly and in good English.
- Try to answer every question.
- Check your answers if you have time at the end.

Turn over ►

P74626RA

©2024 Pearson Education Ltd.
E:1/1/1/1/1/



P 7 4 6 2 6 R A 0 1 2 4



Pearson

Answer ALL questions.

1 (a) The diagram shows a cell found in the human nervous system.

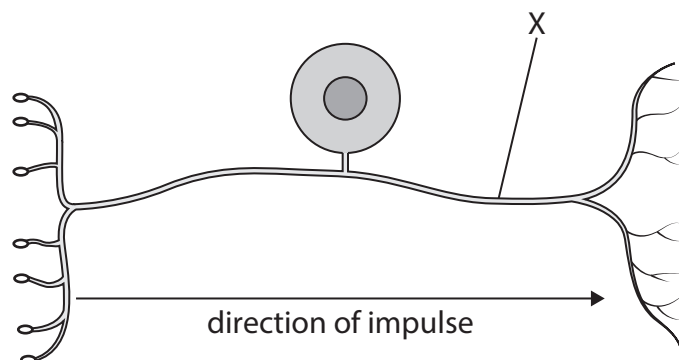

(Source: © Designua/ Shutterstock)

(i) The cell shown in the diagram transmits electrical impulses from a receptor cell to the central nervous system.

State the name of this type of nerve cell.

(1)

(ii) Name the structure labelled X.

(1)

DO NOT WRITE IN THIS AREA

DO NOT WRITE IN THIS AREA

DO NOT WRITE IN THIS AREA



(b) Structures in the skin respond to information from the nervous system.

The diagram shows a section of the skin.

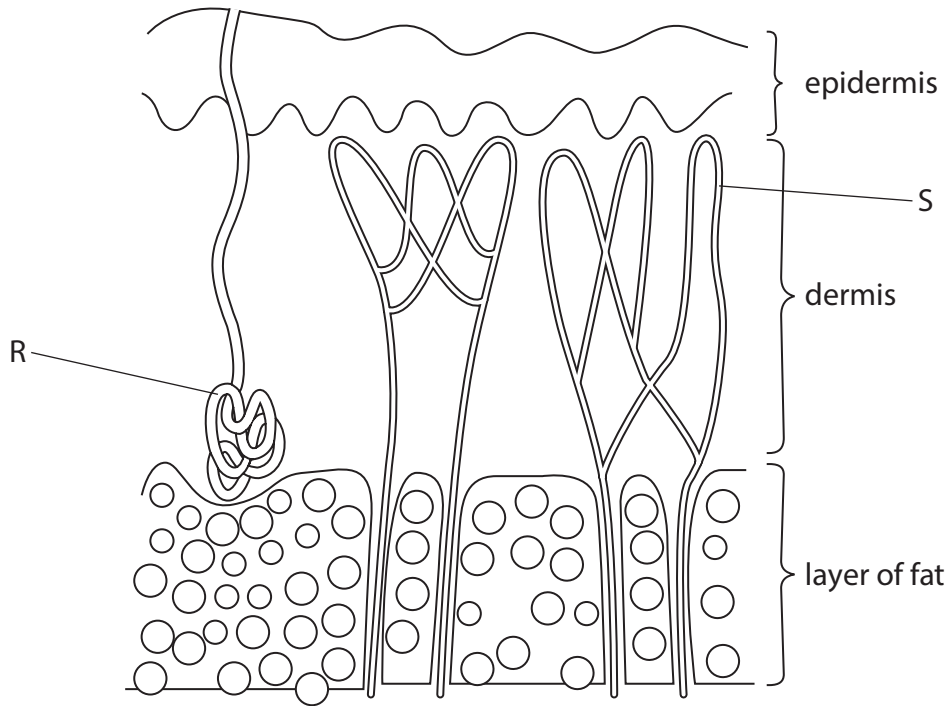

(Source: adapted from Human Physiology and Health, Author David Wright, Publisher Heinemann page 113)

(i) Name part R and part S.

(2)

part R

part S

(ii) Describe how part R helps to cool the body.

(2)



(iii) Describe the role of the layer of fat in maintaining body temperature.

(2)

.....

.....

.....

.....

DO NOT WRITE IN THIS AREA

DO NOT WRITE IN THIS AREA

DO NOT WRITE IN THIS AREA



(c) A student investigates the effect of temperature on receptors in the skin.

This is their method.

- place one hand in hot water
- place the other hand in ice cold water
- after 2 minutes take both hands out of the water
- place both hands in water at room temperature

(i) State one possible hazard with their method.

(1)

.....

.....

(ii) Describe how to reduce the risk of this hazard.

(2)

.....

.....

.....

(iii) When the student placed both hands in the water at room temperature the water felt hot to one hand and ice cold to the other.

Name the structure in the skin that detects temperature.

(1)

.....

.....

(Total for Question 1 = 12 marks)

.....

.....

.....



2 (a) The table gives information about different methods of food preservation.

It also gives information on the length of time in days that each method keeps foods fresh.

Method of food preservation	Time food stays fresh in days
refrigeration	5
freezing	90
pasteurisation	35
vacuum-packed food	14

(i) Draw a bar chart to show the information in the table.

(4)

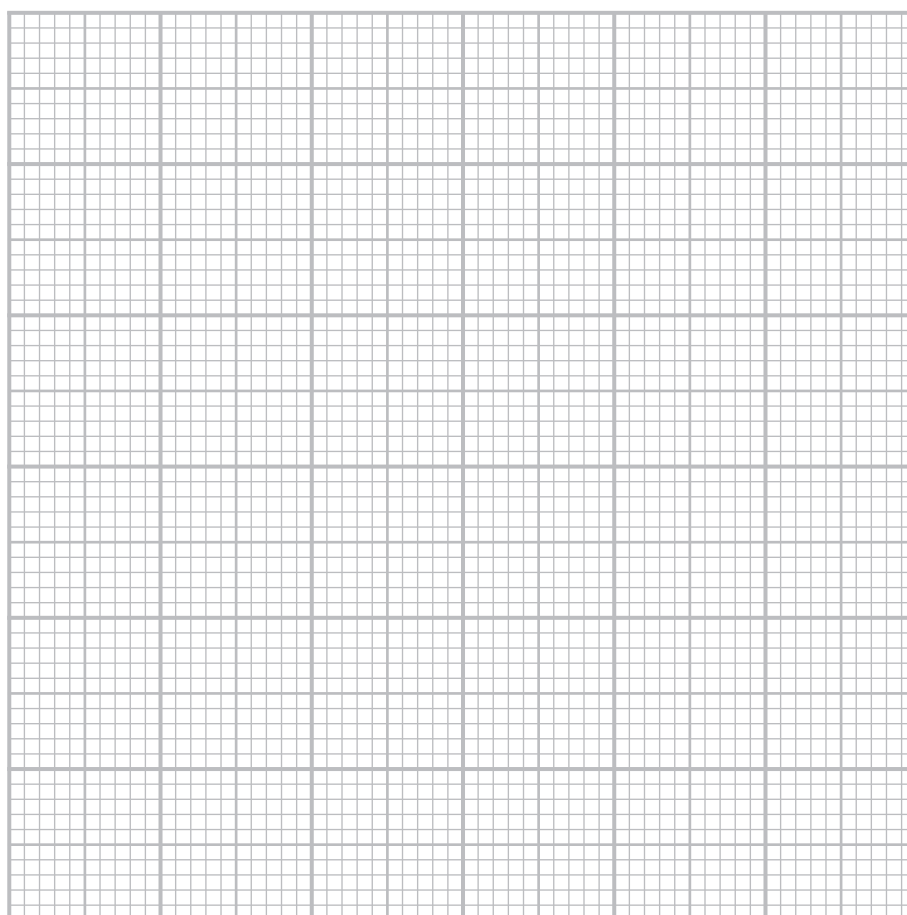

(ii) State how many of the methods shown in the bar chart use heat treatment to preserve food.

(1)

(b) Bacteria can multiply rapidly in food that is not preserved.

Use words from the box to complete the passage about the growth of bacteria.

(6)

exponential	more than	stationary	equal to	lag
dying	death	less than	live	growth

The first stage in the growth of bacterial colonies is known as

the phase. During this phase, bacteria are not dividing.

The second stage of bacterial growth is known as the

..... phase. During this phase the bacteria are multiplying rapidly.

In the third stage, nutrients are running out and the number of dying cells is

..... the number of dividing cells.

Finally, during the phase the number of dividing cells is

..... the number of cells.

(Total for Question 2 = 11 marks)



3 (a) Polydactyly is an inherited condition.

There are several faulty genes on different chromosomes that can cause polydactyly.

(i) State which part of a cell contains the most chromosomes. (1)

(ii) Genes exist in alternative forms.

State the name given to an alternative form of a gene. (1)

(iii) Give one symptom of polydactyly. (1)

(b) Polydactyly is caused by the dominant form of the gene.

The table shows the genotypes of two parents, R and S.





Parent	Genotype
female (R)	Pp
male (S)	pp

(i) Name the term used to describe the genotype of parent R. (1)

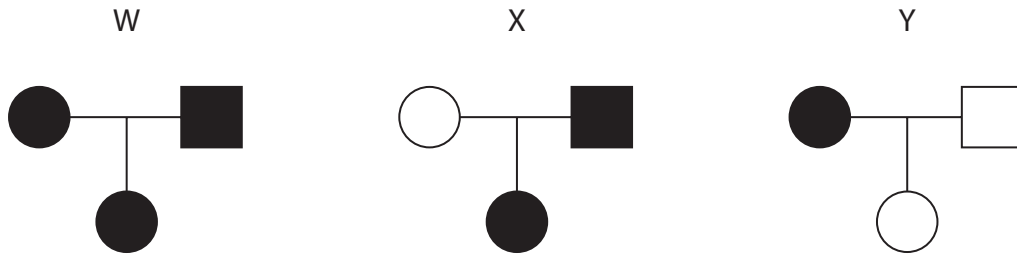

(ii) The family pedigree diagrams show the inheritance of polydactyly.



 male with polydactyly  female with polydactyly
 male without polydactyly  female without polydactyly

Which of the diagrams, W, X or Y, gives the family pedigree for parents R and S?

(1)

(c) A gene is a short section of DNA.

Describe the structure of DNA.

(4)

.....

.....

.....

.....

.....

.....

.....

.....

.....

.....

(Total for Question 3 = 9 marks)



4 (a) The diagram shows some scientific equipment.

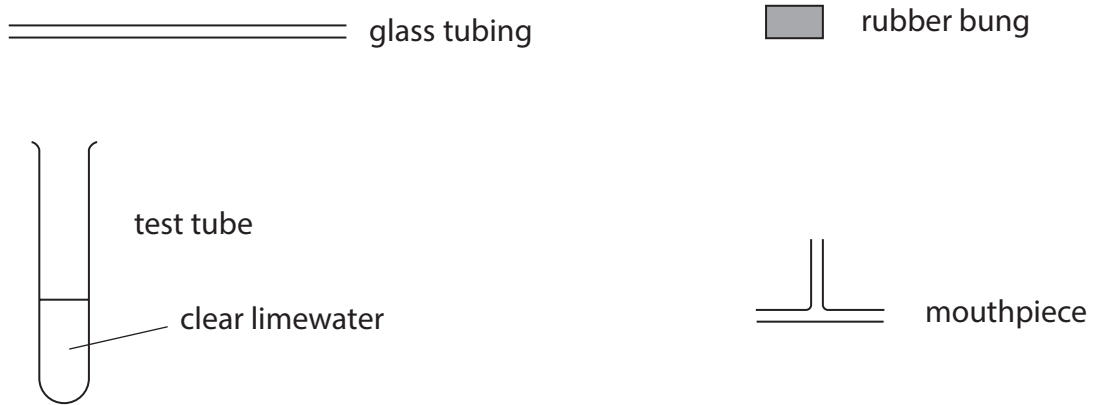

(i) Draw a diagram to show how this equipment is set up to investigate the difference between the carbon dioxide concentration of inspired air and of expired air.

(3)

DO NOT WRITE IN THIS AREA

DO NOT WRITE IN THIS AREA

DO NOT WRITE IN THIS AREA



(ii) State one safety precaution in this investigation.

(1)

.....

.....

.....

(b) A student investigates their breathing rate at rest, after gentle exercise and again after vigorous exercise.

The student repeats each exercise three times.

The student's mean results are shown in the table.

Mean breathing rate in breaths per minute		
at rest	after gentle exercise	after vigorous exercise
14	19	50

(i) Give one control variable in this investigation.

(1)

.....

.....

(ii) Explain how the breathing rate after vigorous exercise benefits working muscles.

(4)

.....

.....

.....

.....

.....

.....

.....

.....

.....

.....

.....

(Total for Question 4 = 9 marks)



(ii) State the independent variable in this investigation.

(1)

(b) Explain how enzyme activity is affected by low temperatures.

(4)

(Total for Question 5 = 10 marks)

DO NOT WRITE IN THIS AREA

DO NOT WRITE IN THIS AREA

DO NOT WRITE IN THIS AREA



DO NOT WRITE IN THIS AREA

DO NOT WRITE IN THIS AREA

DO NOT WRITE IN THIS AREA

BLANK PAGE



- 6 (a) Humans have a small surface area to volume ratio (SA:V) compared with some other organisms.

Cube X represents a human.

Cube Y represents an organism with a larger SA:V.

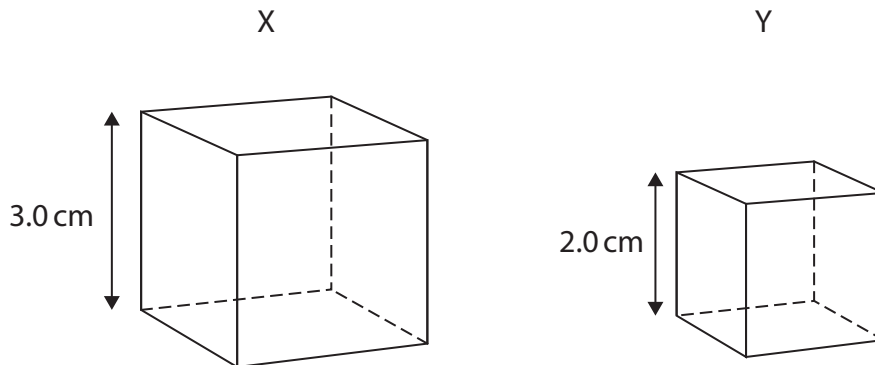

The table gives the SA:V of cube Y.

Cube	Surface area in cm^2	Volume in cm^3	SA:V
X			
Y	24.0	8.0	3:1

- (i) Calculate the surface area of cube X.

(2)

surface area = cm^2

- (ii) Calculate the volume of cube X.

(2)

volume = cm^3

- (iii) Calculate the SA:V of cube X.

(2)

SA:V = : 1



DO NOT WRITE IN THIS AREA

DO NOT WRITE IN THIS AREA

DO NOT WRITE IN THIS AREA

(b) Multicellular organisms, with a small SA:V ratio, such as humans, need an efficient transport system to deliver substances to body cells.

Describe the role of the human blood transport system in delivering substances to body cells.

(5)

Area with horizontal dotted lines for writing the answer.



(c) Bacteria are able to exchange materials directly with their environment as they have a very high SA:V ratio.

They do not have an internal transport system.

Describe how bacteria exchange materials with their environment.

(2)

.....

.....

.....

.....

.....

(Total for Question 6 = 13 marks)

DO NOT WRITE IN THIS AREA

DO NOT WRITE IN THIS AREA

DO NOT WRITE IN THIS AREA



7 (a) The list gives some structures found in the thorax.

- intercostal muscles
- ribs
- diaphragm

Describe how these structures work together during inhalation.

(4)

.....

.....

.....

.....

.....

.....

.....

.....

.....

.....

.....

.....

.....

.....

.....

.....

.....

.....

.....

.....

.....

.....

.....

(b) Describe the role of chemoreceptors in the carotid arteries.

(2)

.....

.....

.....

.....



(c) The graph shows different lung volumes.

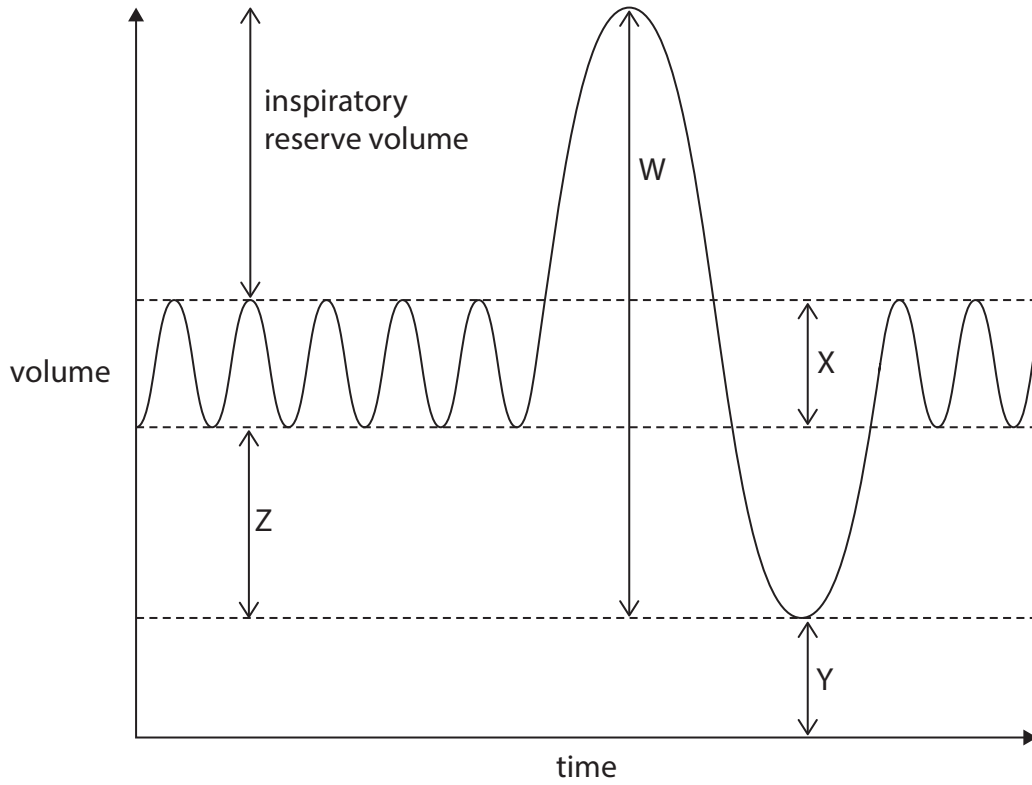

(Source: <https://www.indis.co.uk/education/how2/measure-lung-volume/>)

(i) Give the name of the lung volume represented by letter X. (1)

(ii) Give the name of the lung volume represented by letter Y. (1)

(iii) Give the name of the lung volume represented by letter W. (1)

(Total for Question 7 = 9 marks)

DO NOT WRITE IN THIS AREA

DO NOT WRITE IN THIS AREA

DO NOT WRITE IN THIS AREA



8 (a) The diagram represents a modern sewage works.

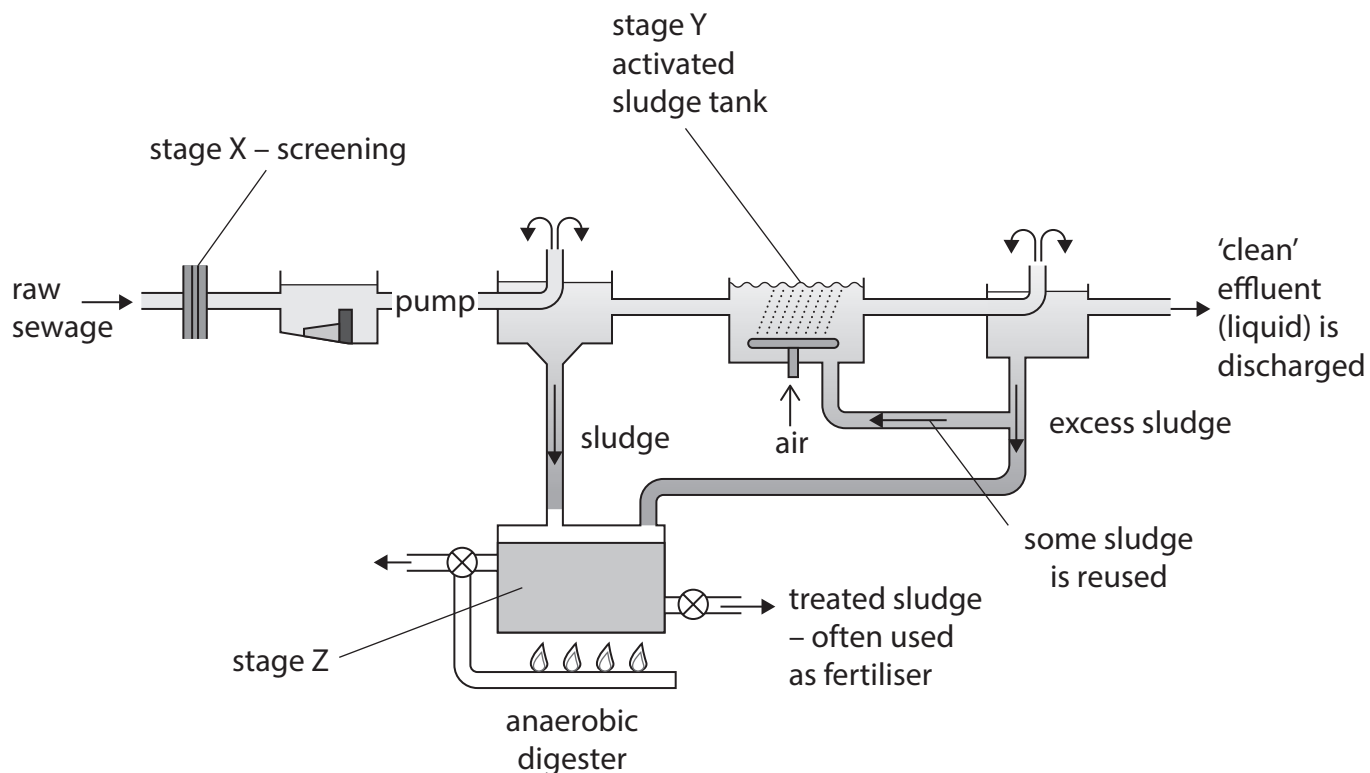

(Source: adapted from Human Physiology and Health page 215. Publisher Heinemann. Author David Wright)

(i) Describe the process that happens at stage X.

(2)

.....

.....

.....

.....



DO NOT WRITE IN THIS AREA

DO NOT WRITE IN THIS AREA

DO NOT WRITE IN THIS AREA

(b) Haemophilia is a sex-linked genetic condition that affects the blood.

(i) Describe what is meant by a sex-linked genetic condition.

(2)

.....

.....

.....

.....

(ii) State one effect that haemophilia will have on an individual.

(1)

.....

.....

.....

(Total for Question 9 = 10 marks)

TOTAL FOR PAPER = 90 MARKS



DO NOT WRITE IN THIS AREA

DO NOT WRITE IN THIS AREA

DO NOT WRITE IN THIS AREA

BLANK PAGE

