

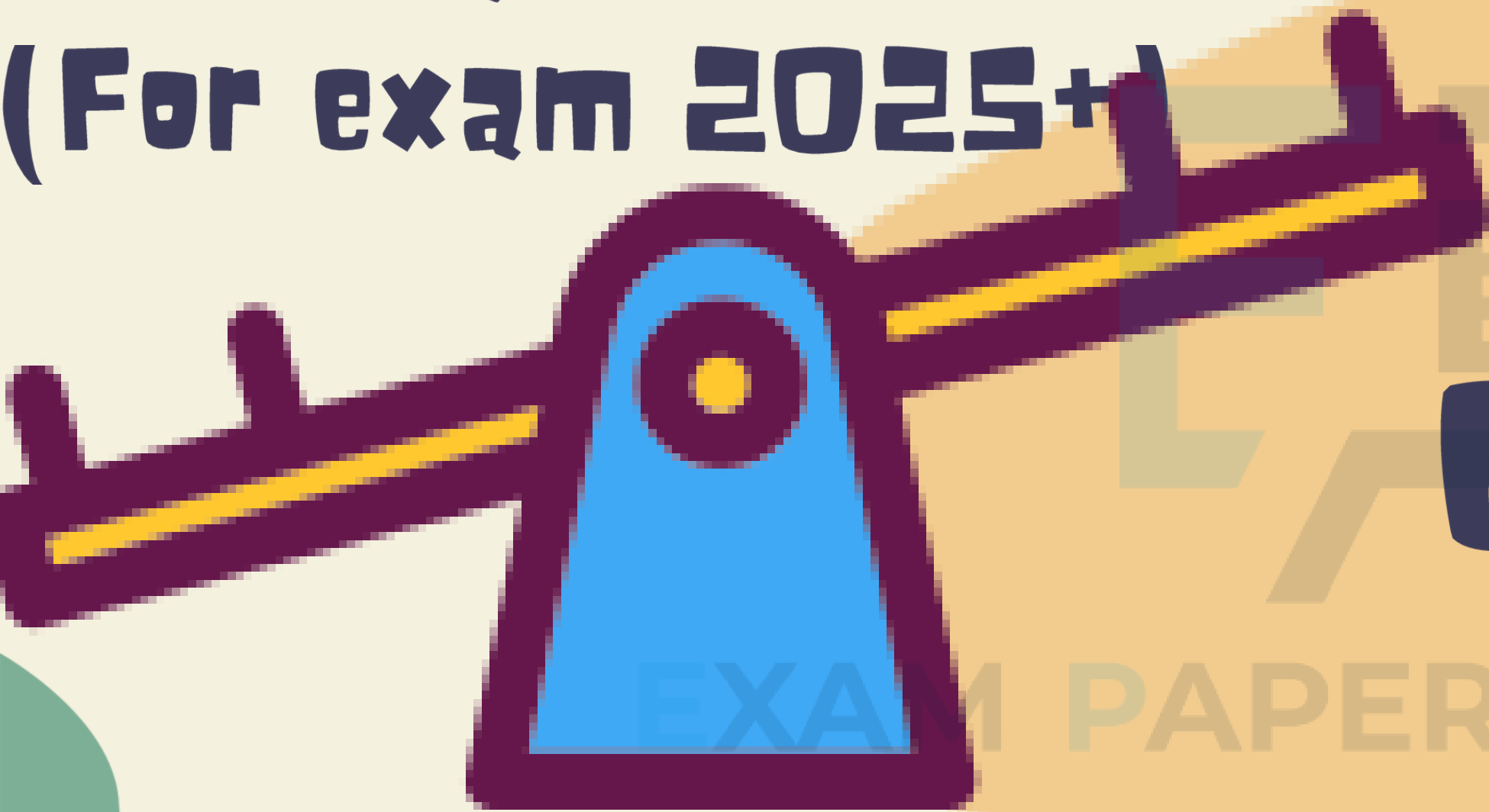

EXAM PAPERS PRACTICE

**CIE IGCSE Physics for board
0625 and 0972
(For exam 2025+)**



**Turning
effects of
a force**

DEFINITION

A moment typically refers to the turning effect produced by a force around a pivot point, calculated as the product of the force and the perpendicular distance from the pivot to the line of action of the force.

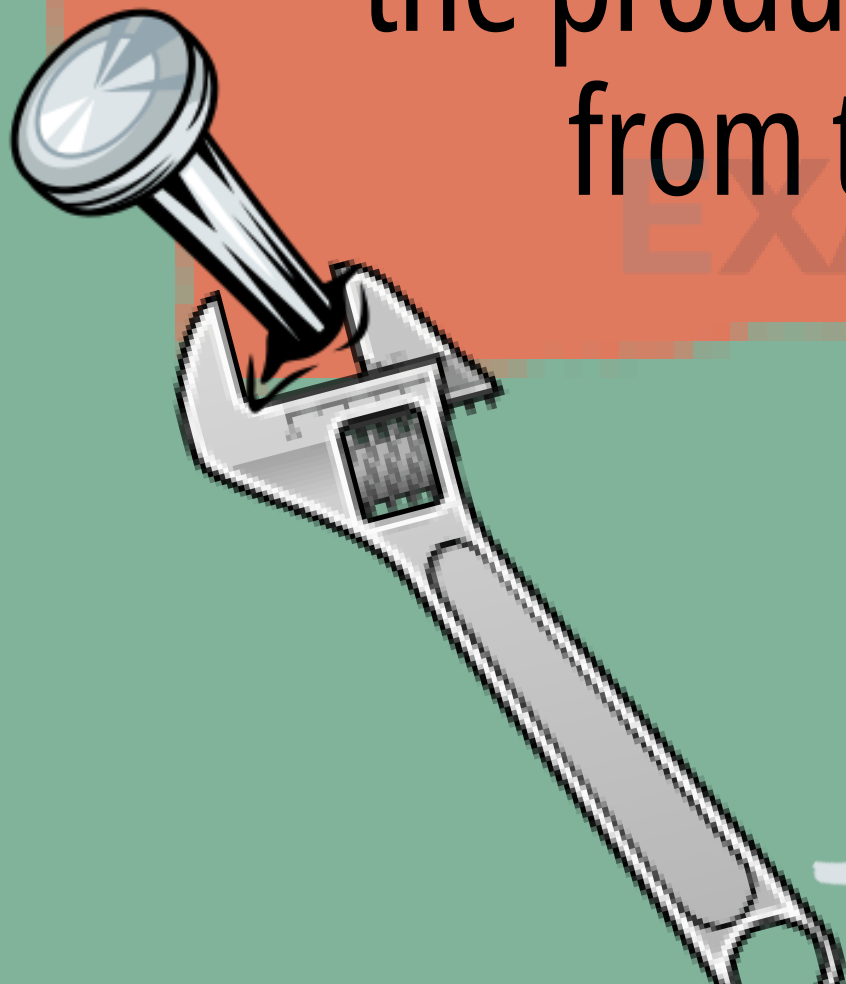

DEFINITION

A pivot is a fixed point or axis around which a rigid body or lever rotates or oscillates. It serves as the centre or point of support for rotational motion or balance.

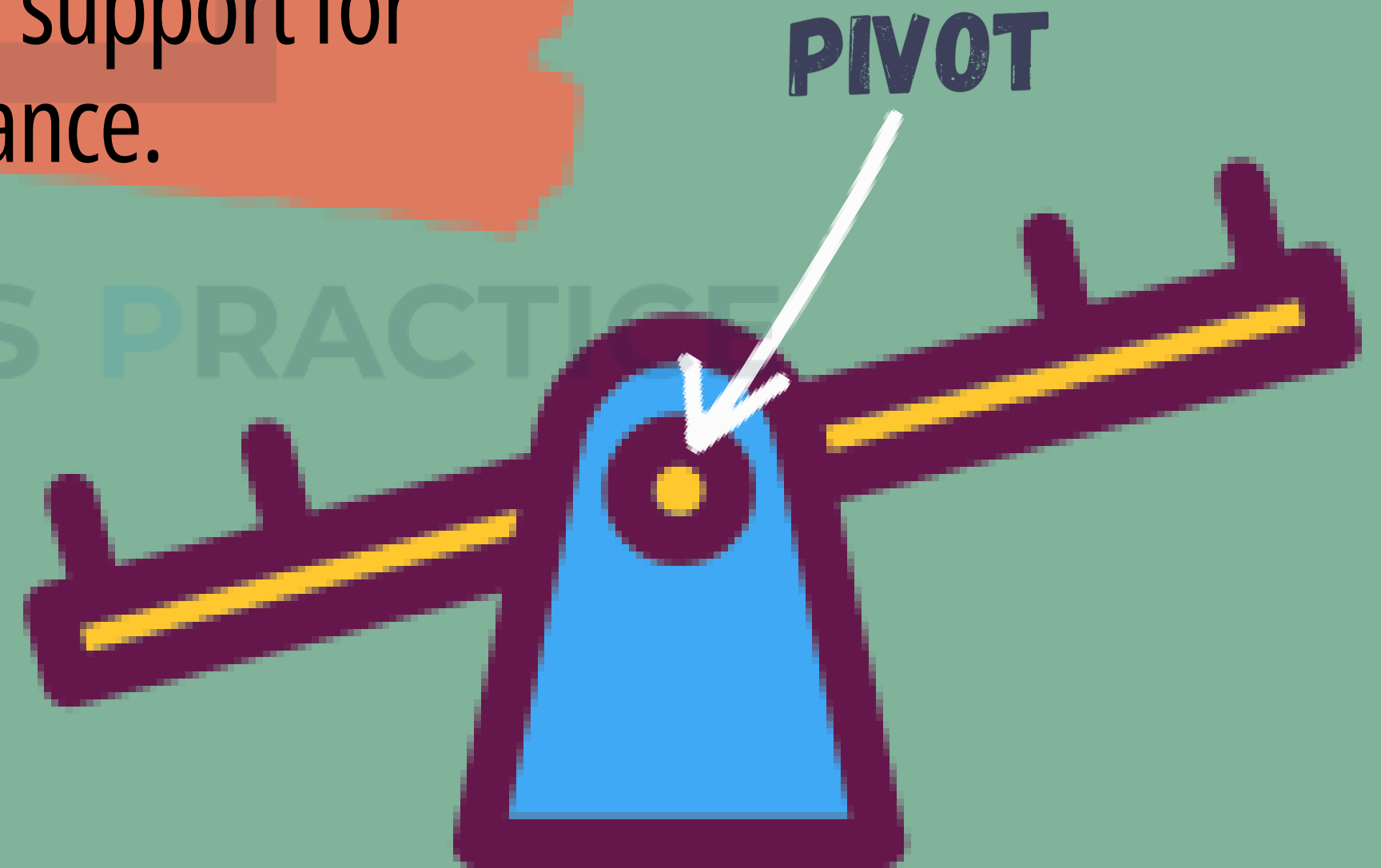
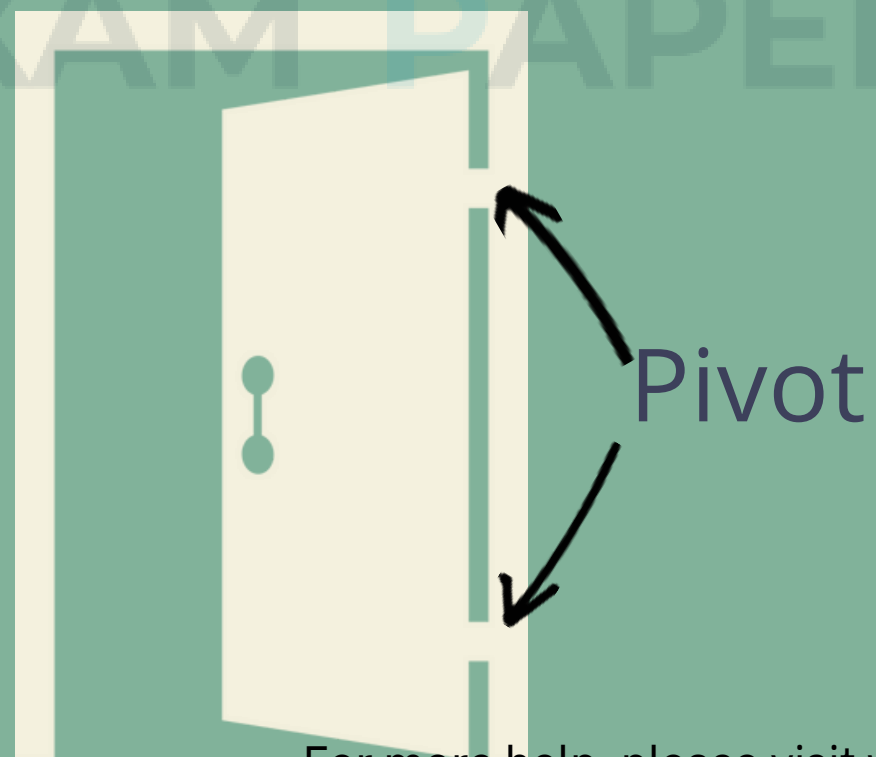

Factors affecting moment

1

less moment

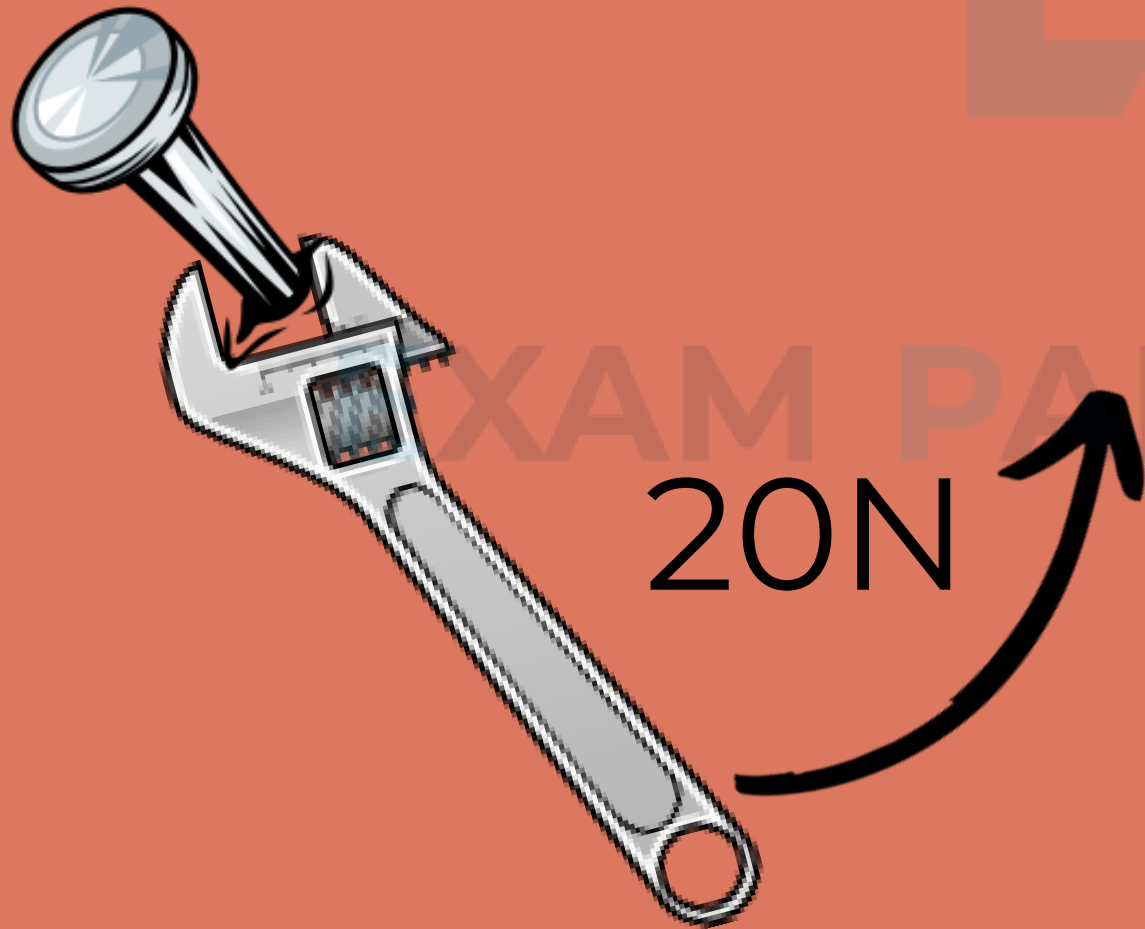

more moment

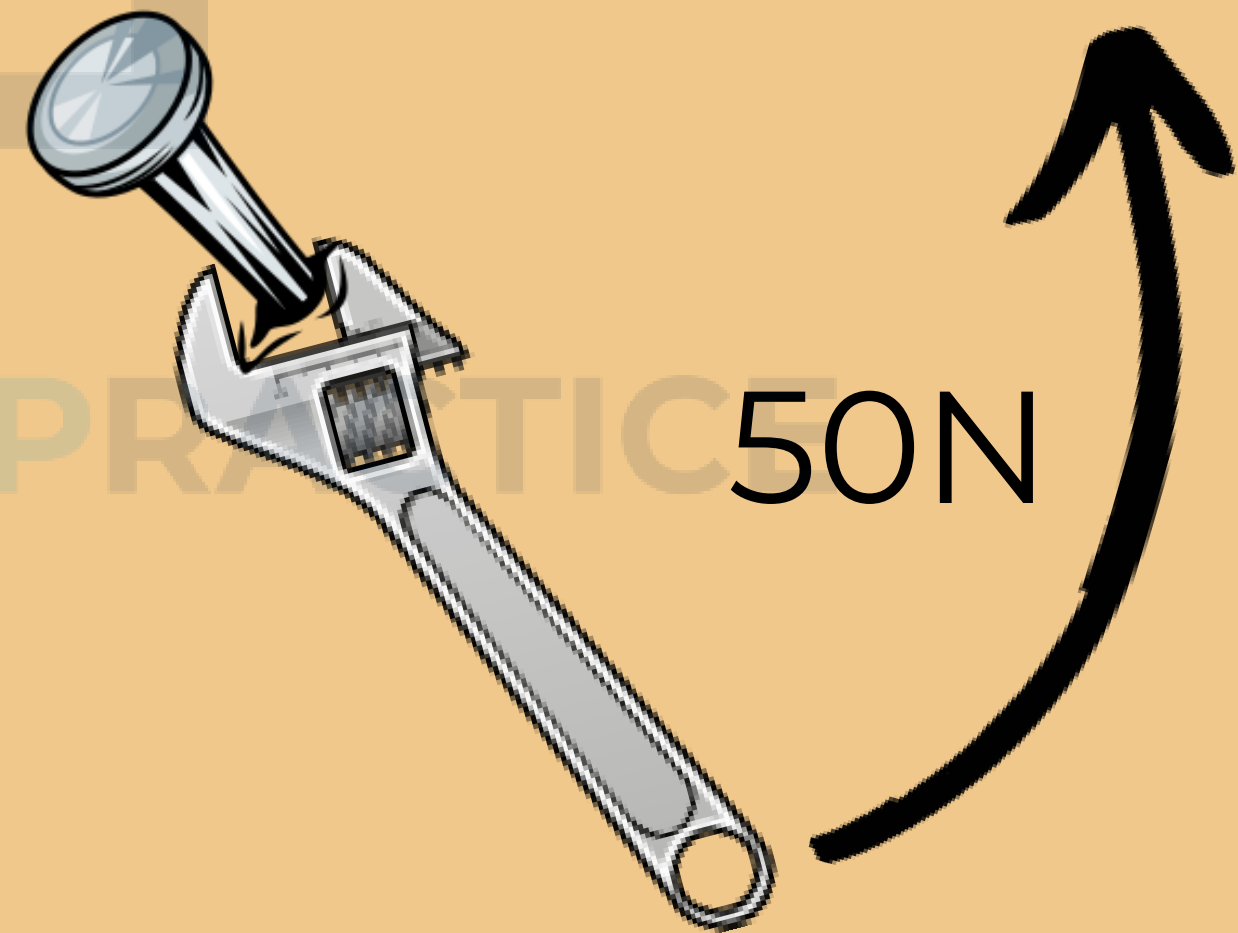

Factors affecting moment

2

less moment

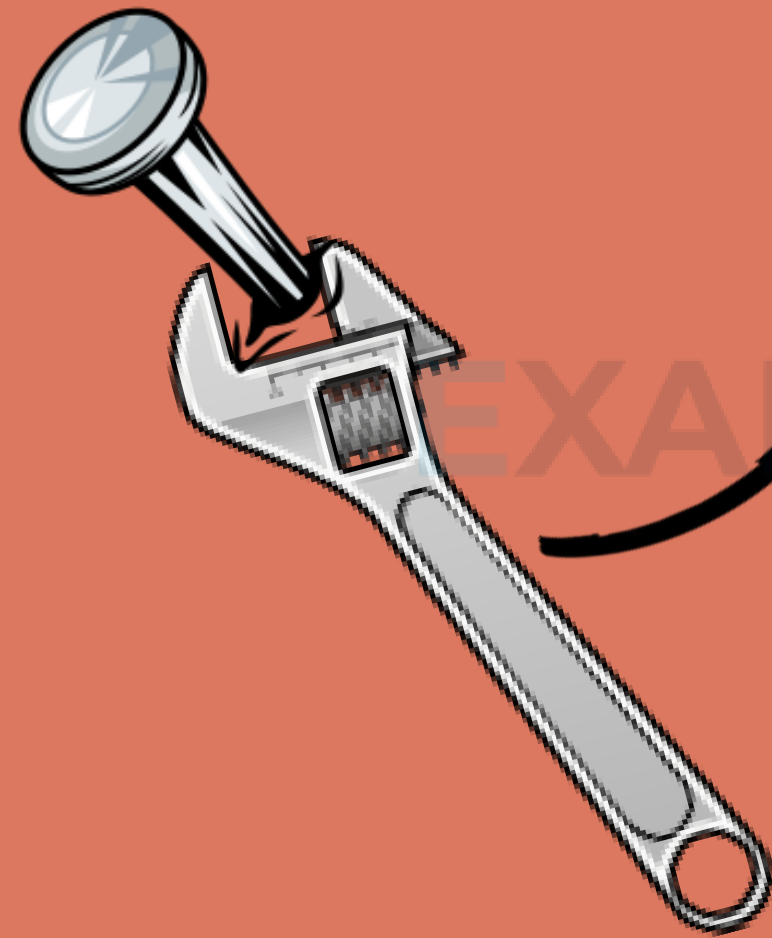

Apply for here

more moment

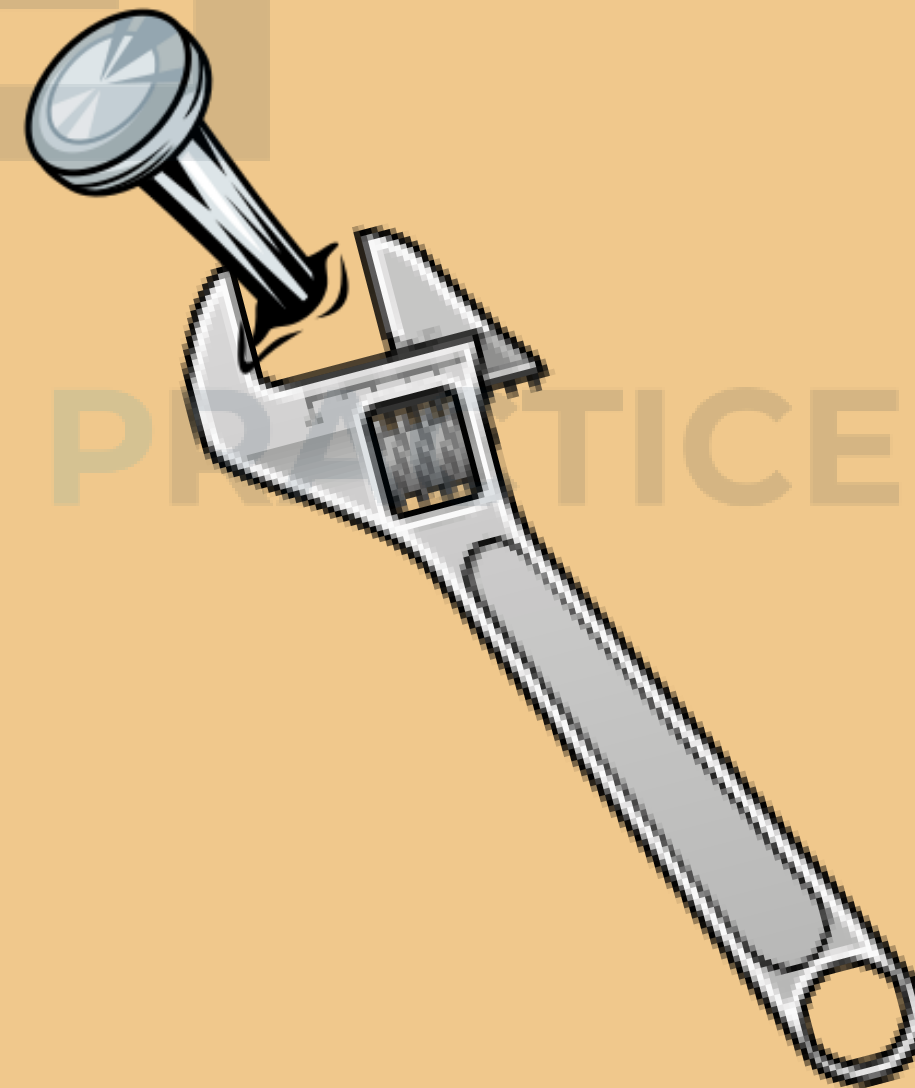

Apply for here

Factors affecting moment

The moment of a force is greatest if it acts at 90° to the object it acts on.

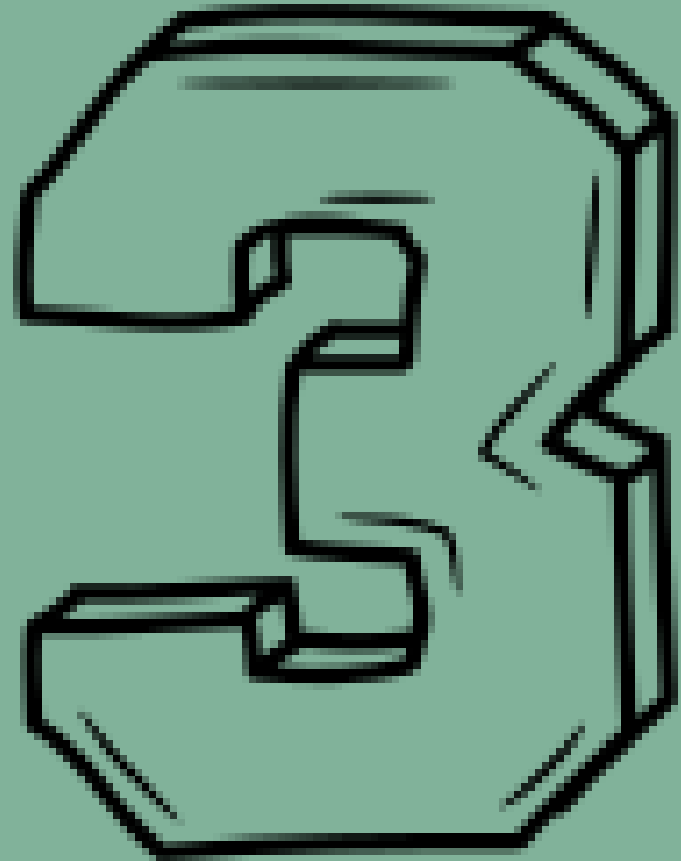

Moment examples

To maximize the leverage when using a crowbar to lift a heavy rock, pull near the end of the bar and at a 90-degree angle to achieve the greatest turning effect possible.



Moment examples

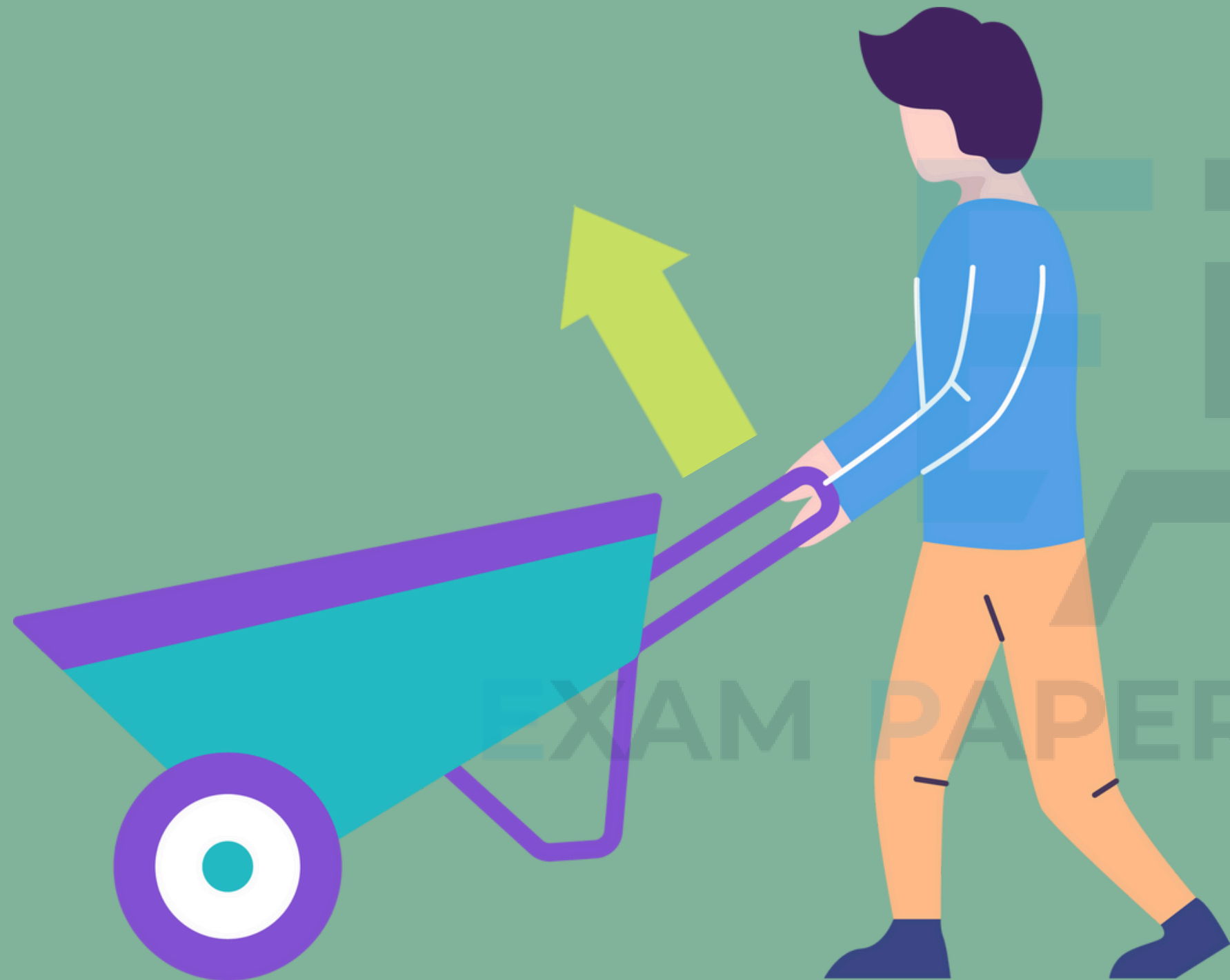

Long handles increase the leverage or moment of the lifting force.

Lifting a load in a wheelbarrow

Moment Formula

FORMULA

force (x) perpendicular distance from the pivot
(Unit = Nm)

EXAM PAPERS PRACTICE

Worked Example

Question

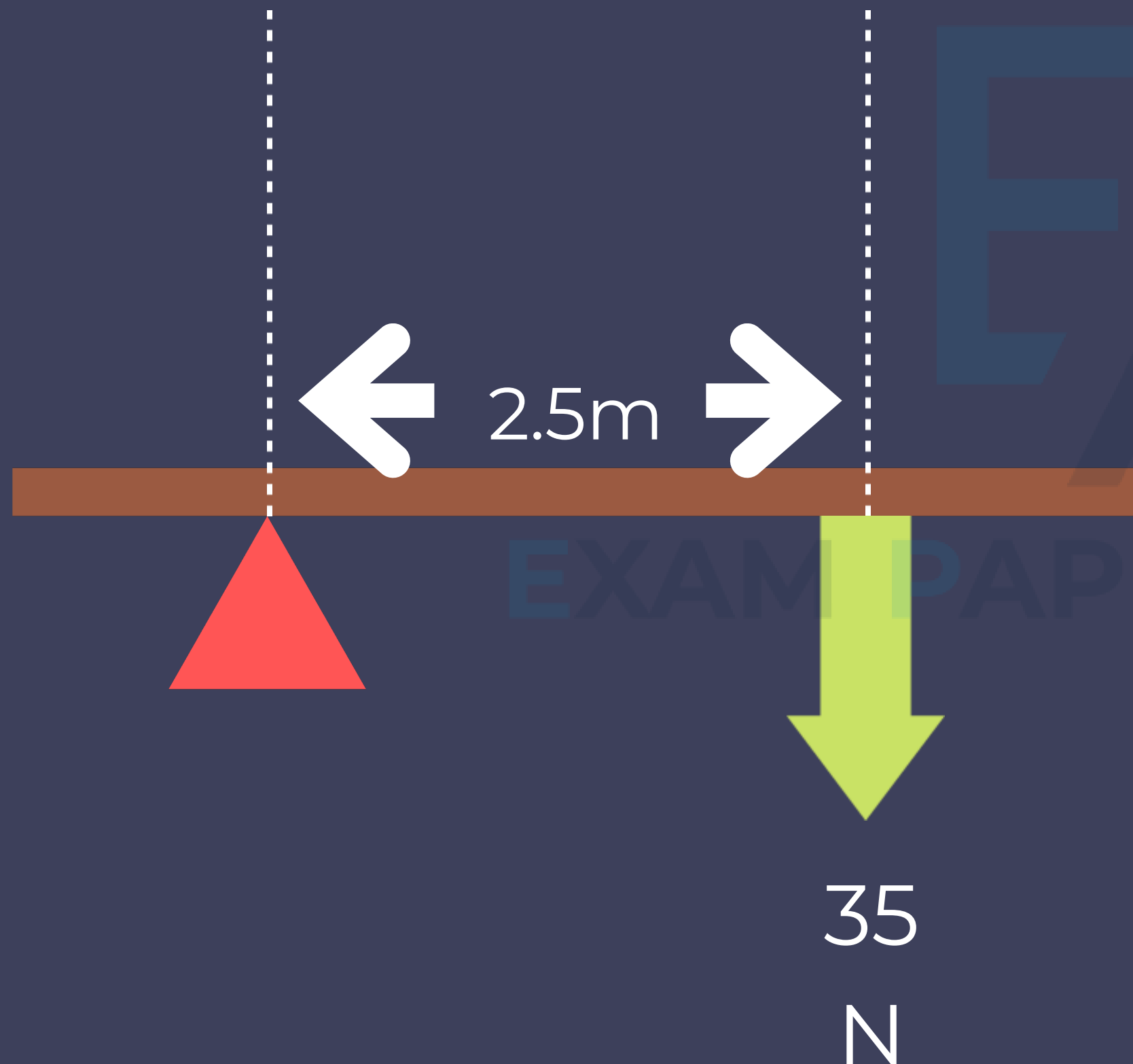

“

Calculate the moment of the force.

”

N

Worked Example

Solution

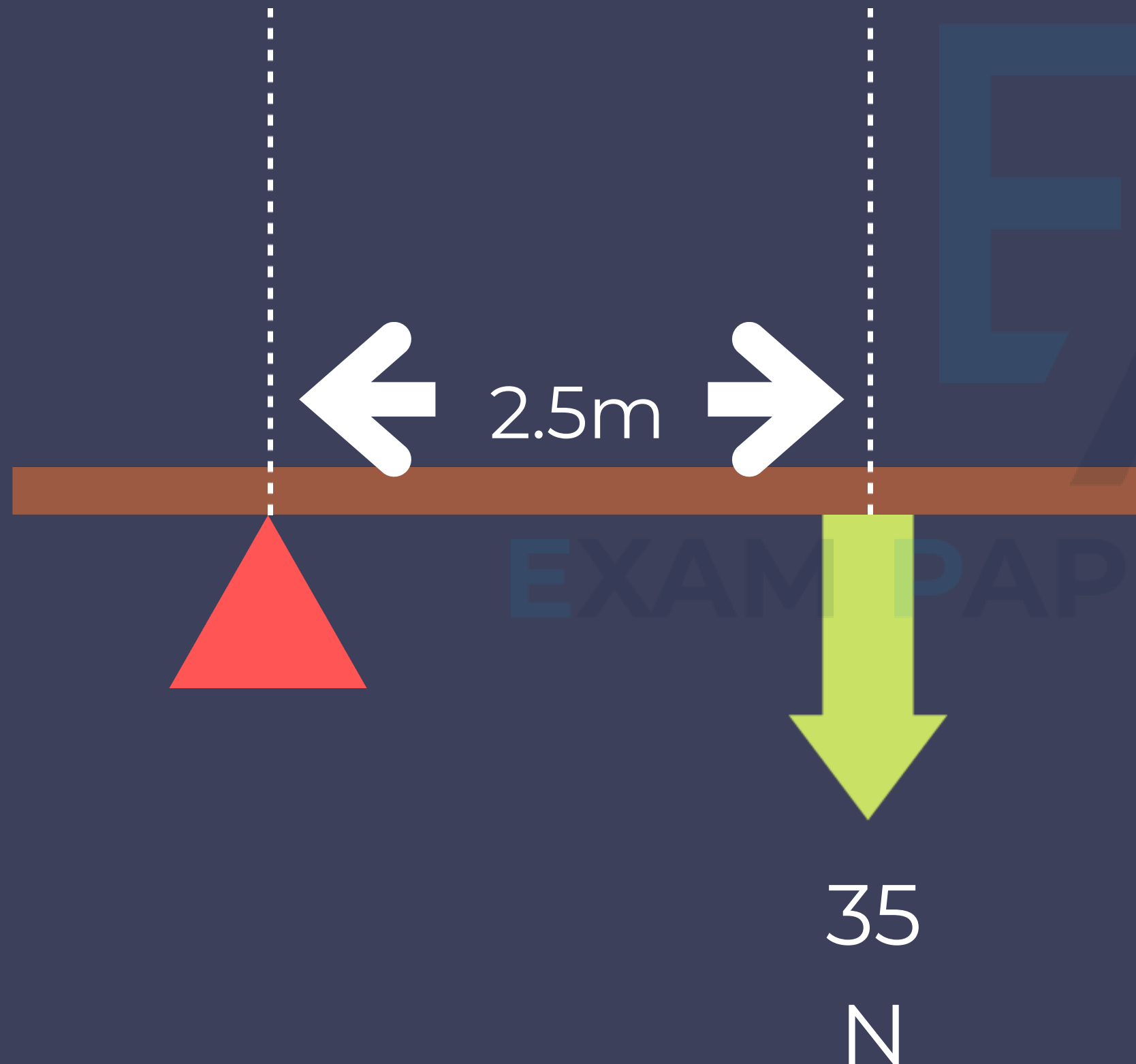

35

N

Worked Example

Solution

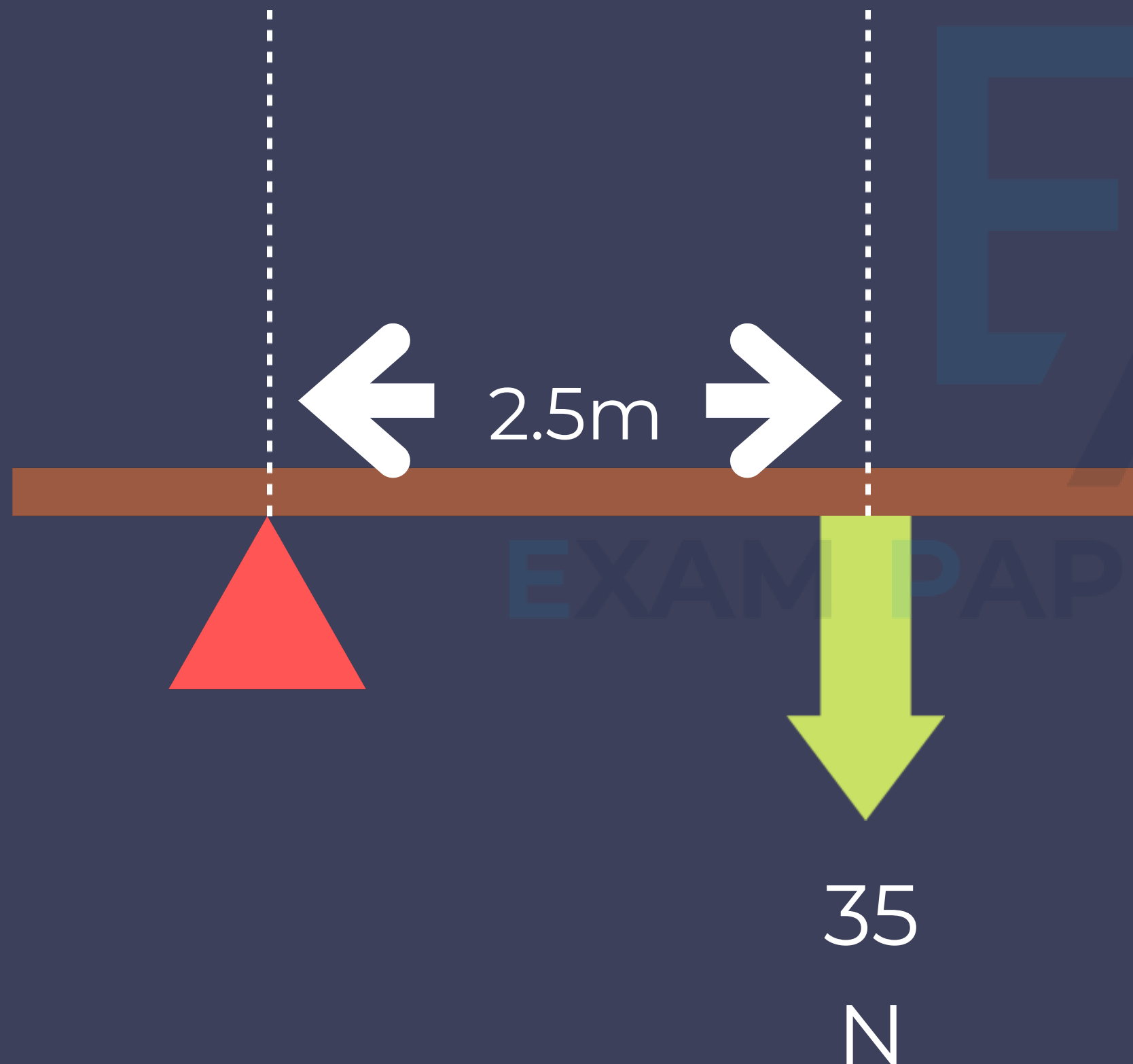

— “ —————

moment = force x
perpendicular distance

$$\text{moment} = 35\text{N} \times 2.5\text{m}$$

$$\text{moment} = 87.5 \text{ Nm}$$

————— ” —

N

Equilibrium

A beam is a long, rigid object that is pivoted at a point. Eg. A see saw.

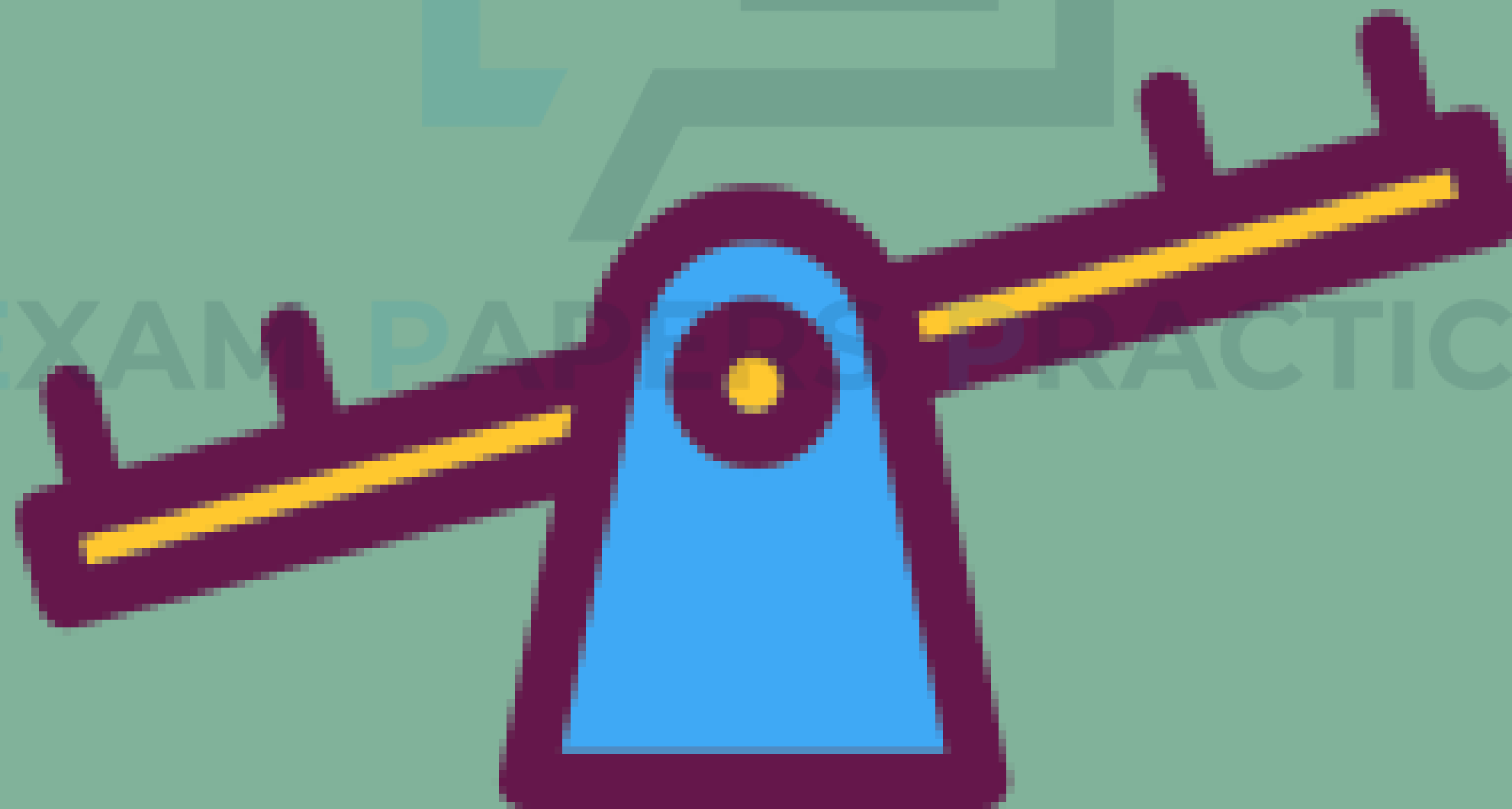

Equilibrium

When a beam is balanced,
we say it is in equilibrium.

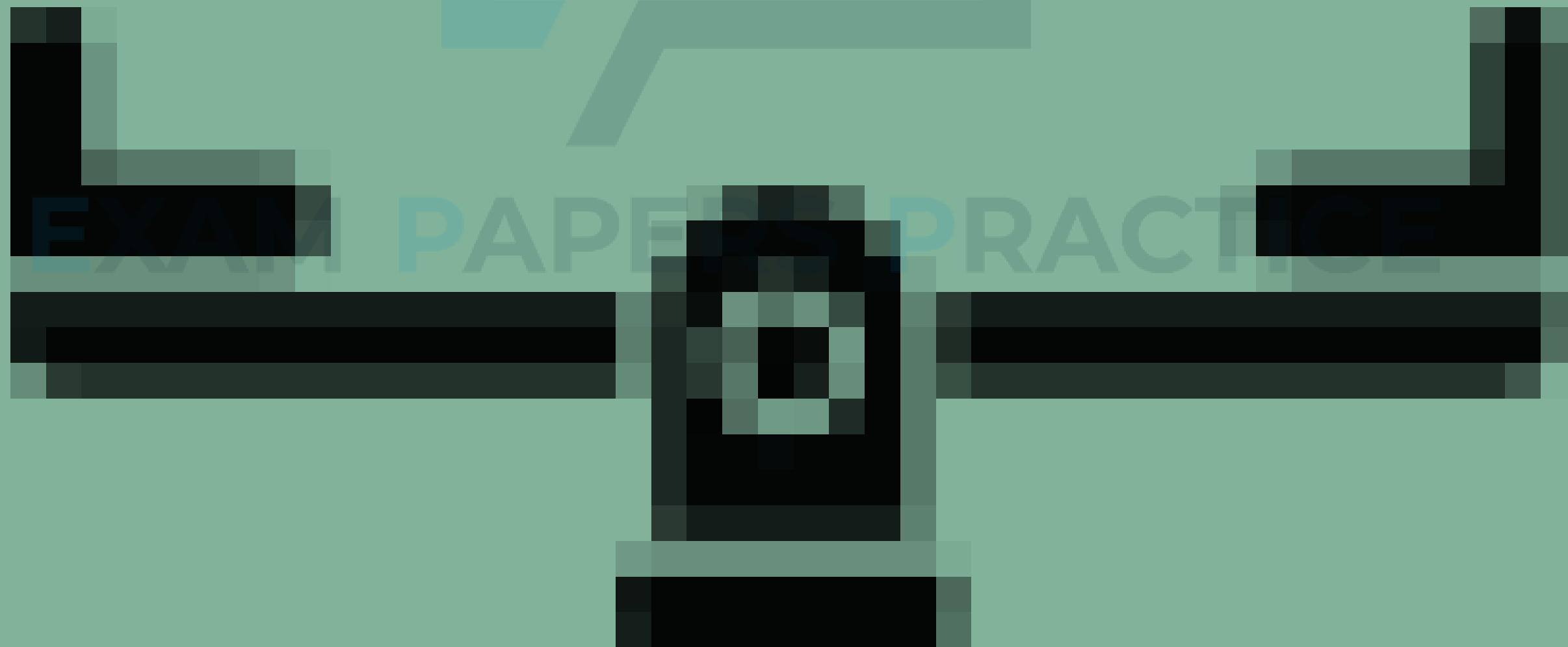

When an object is in equilibrium:

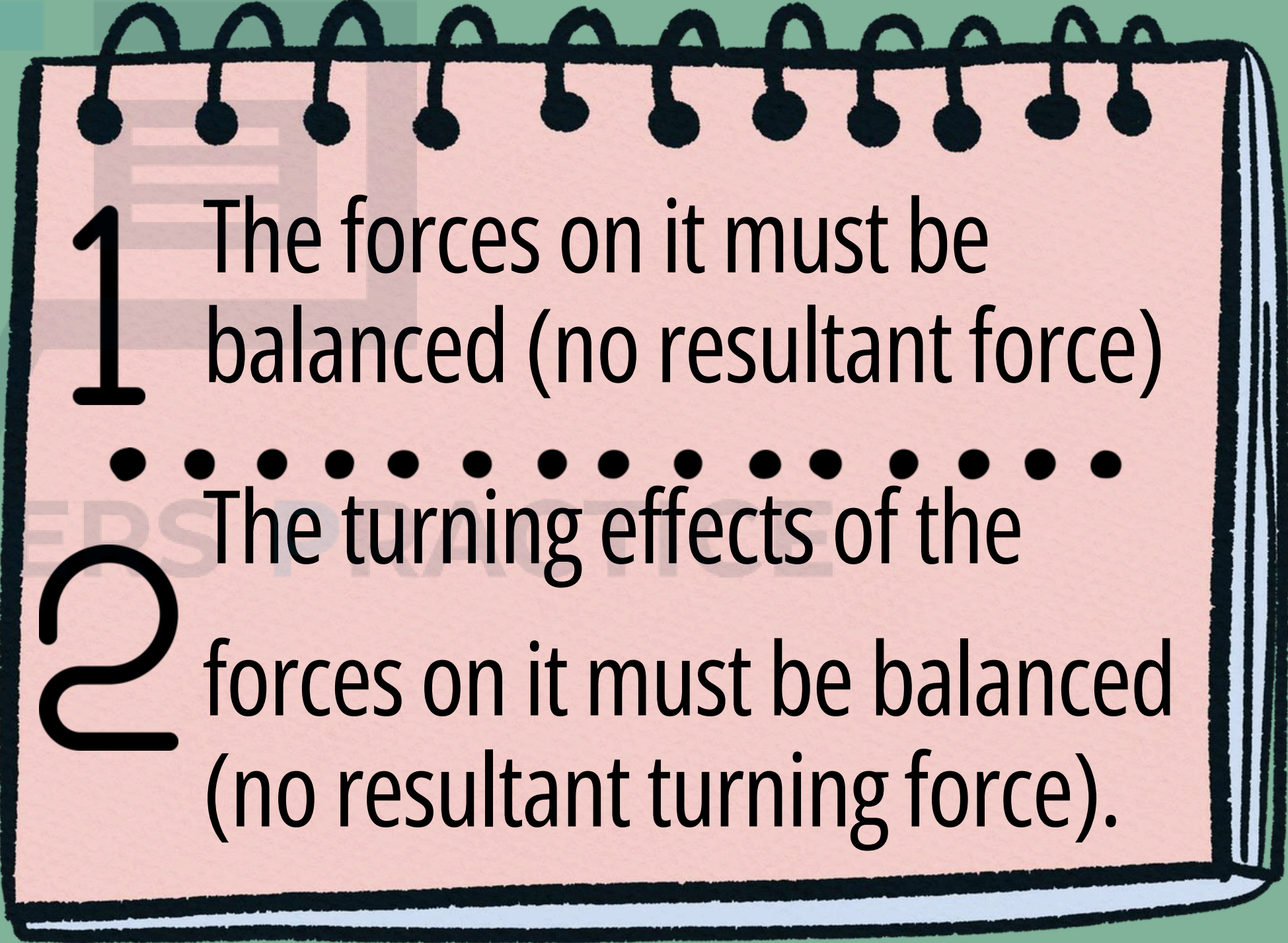

1 The forces on it must be balanced (no resultant force)

•••••
2 The turning effects of the forces on it must be balanced (no resultant turning force).

Definition of equilibrium

No net force

(& ~~no net moment~~ ~~act~~ ~~on~~ ~~a~~ ~~body~~)
(Clockwise moment = anticlockwise moment)

Worked Example

Question

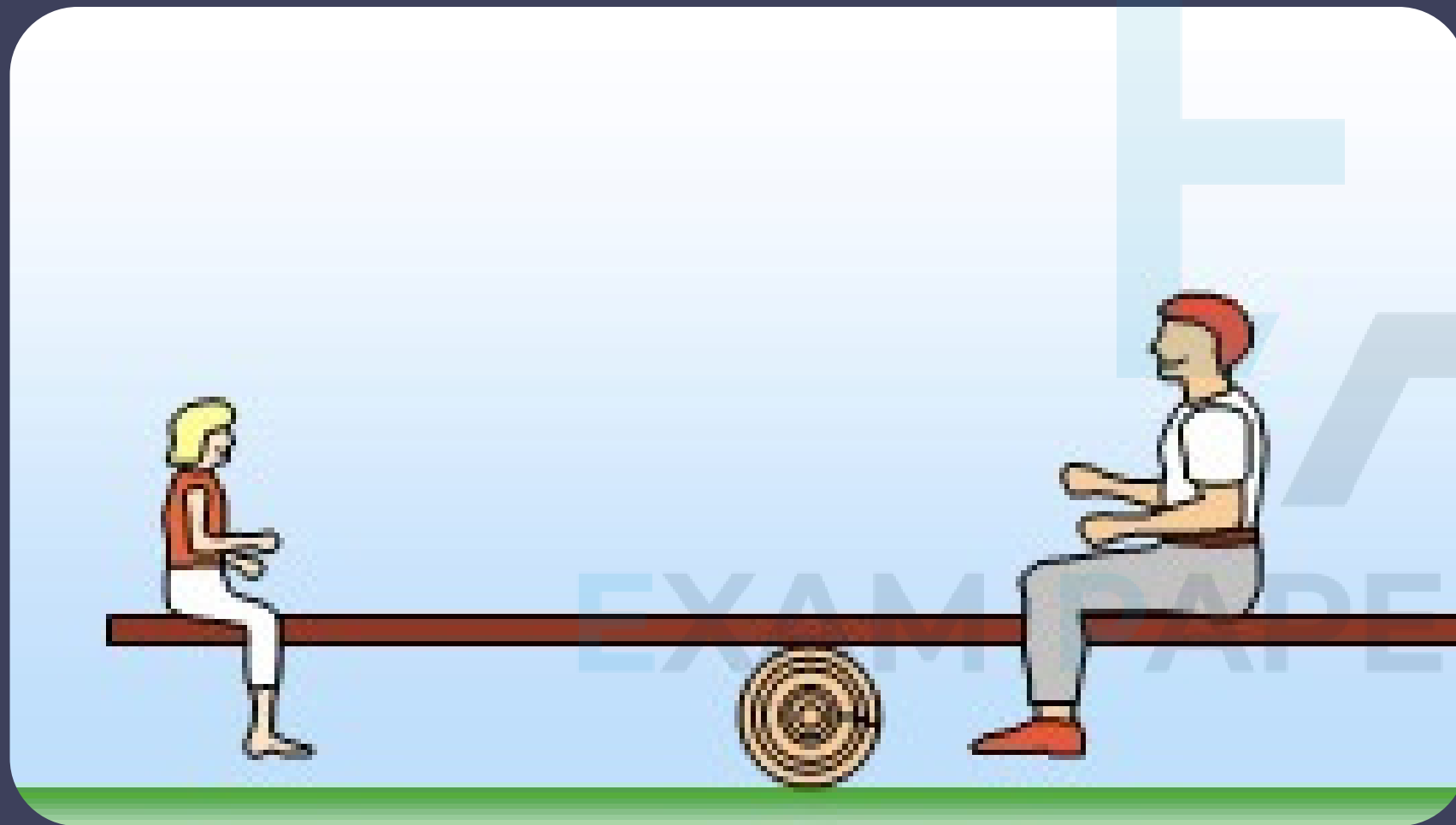

— “ —

The daughter in the figure below has a weight of 500N and is sitting 2.0 metres to the left of the pivot. Her father has a weight of 800N. How far to the right of the pivot should he sit so that the see-saw is **BALANCED** (= must fulfil equilibrium)?

— ” —

Worked Example

Solution

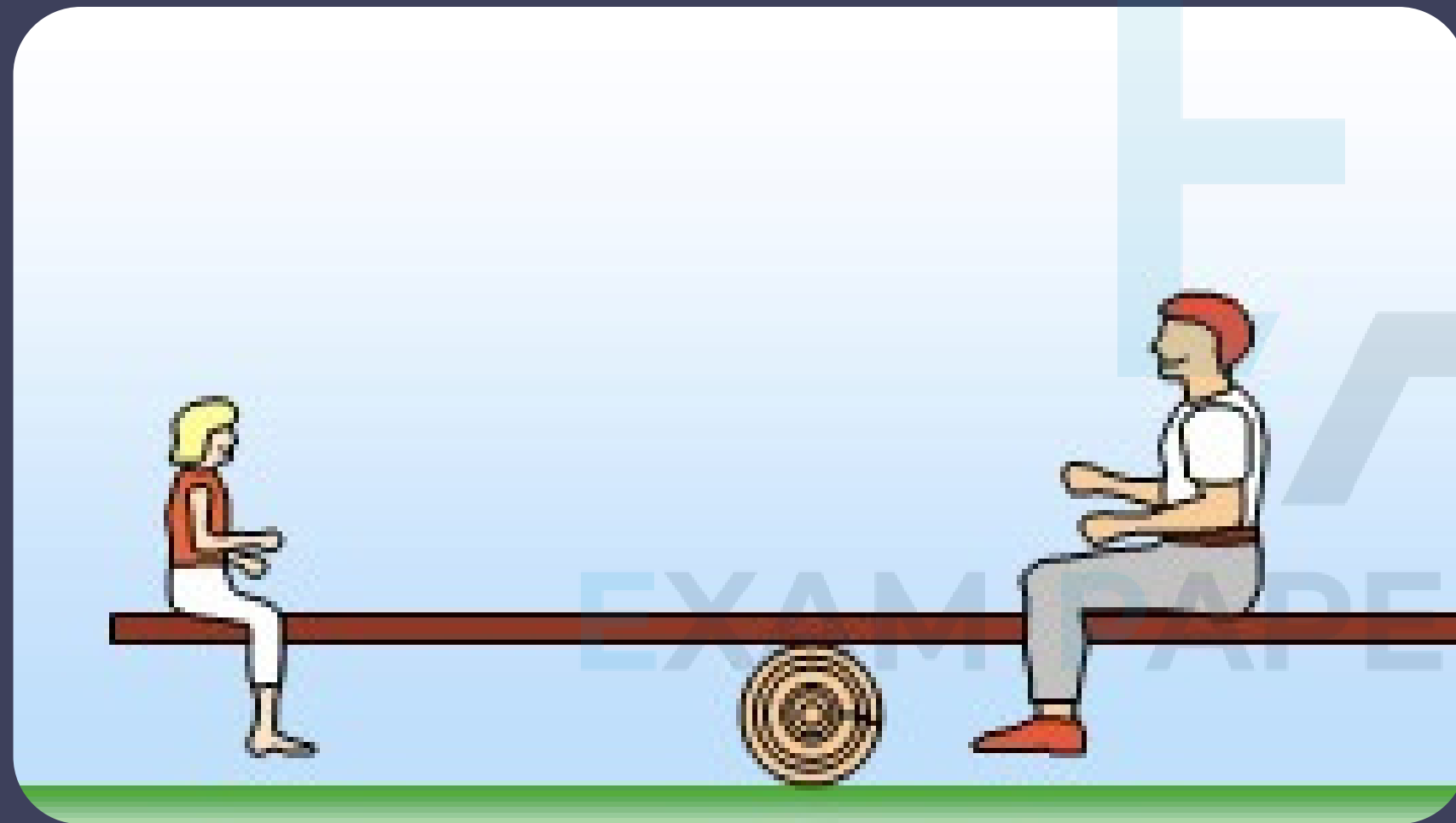

“ clockwise moment = anticlockwise moment ”

Worked Example

Solution

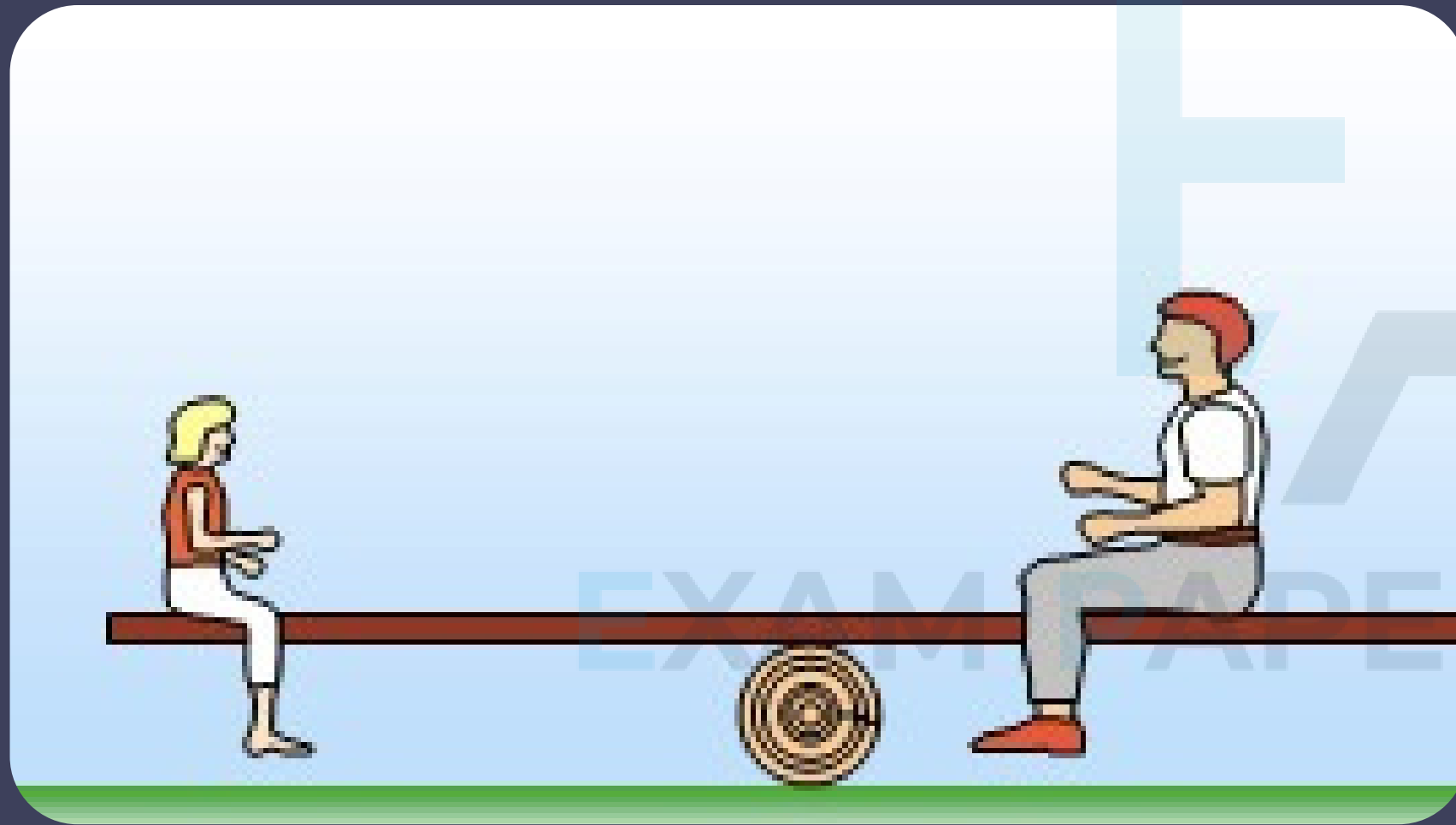

“
clockwise moment =
anticlockwise moment

$$500 \times 2 = 800 \times \text{distance}$$

$$\begin{aligned} \text{distance} &= 1000 / 800 \\ &= 1.25 \text{ m} \end{aligned}$$

”

Worked Example

Question

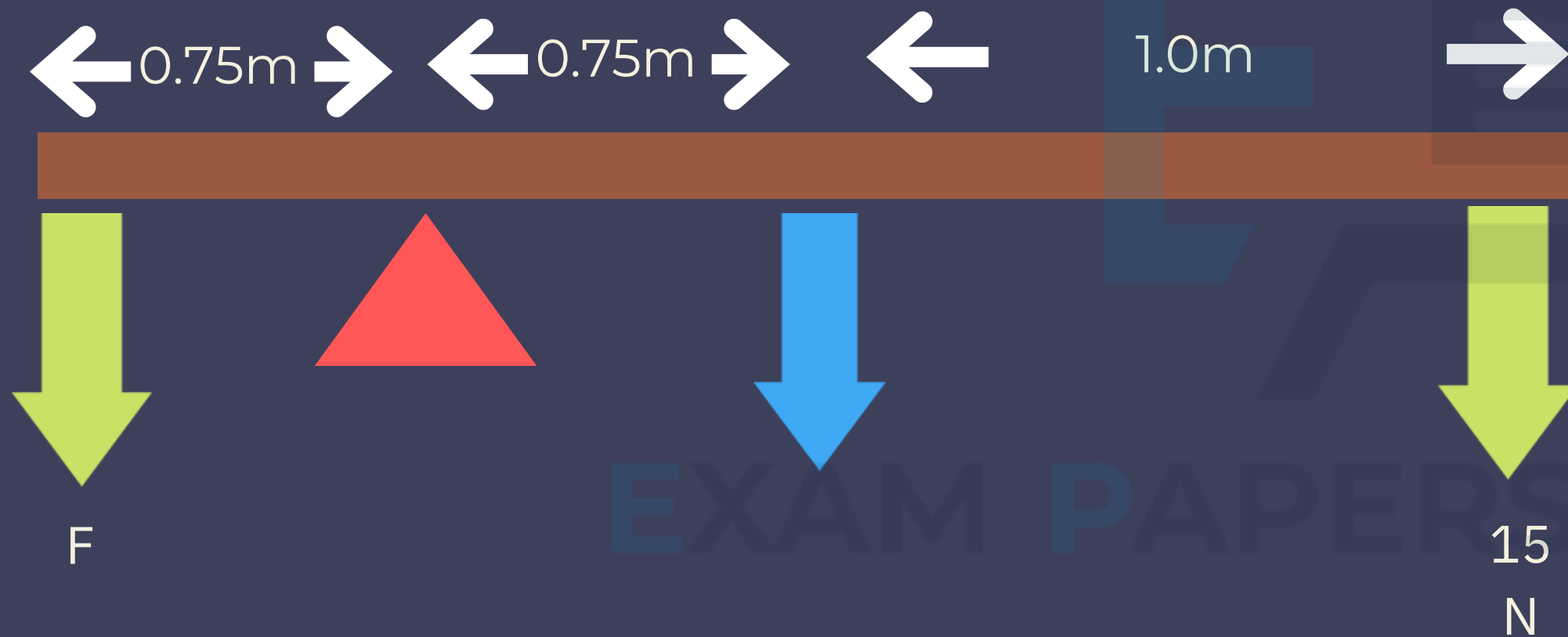

— “ —————

The beam depicted below is 2.5 meters long and weighs 30 N. It is pivoted as shown.

A downward force of 15 N acts at one end. What downward force F must be applied at the other end to balance the beam?

————— ” —

Worked Example

Solution

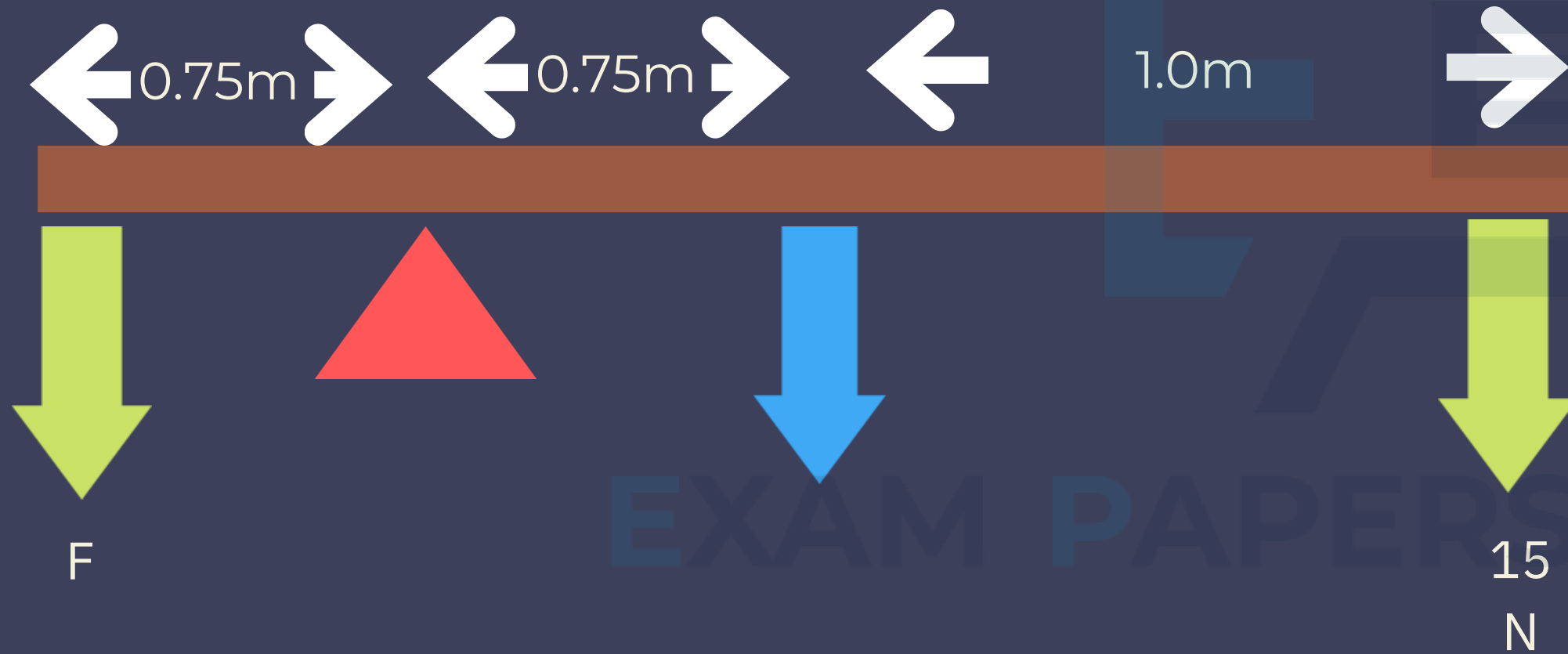

“ Clockwise moment

Anticlockwise moment

”

Worked Example

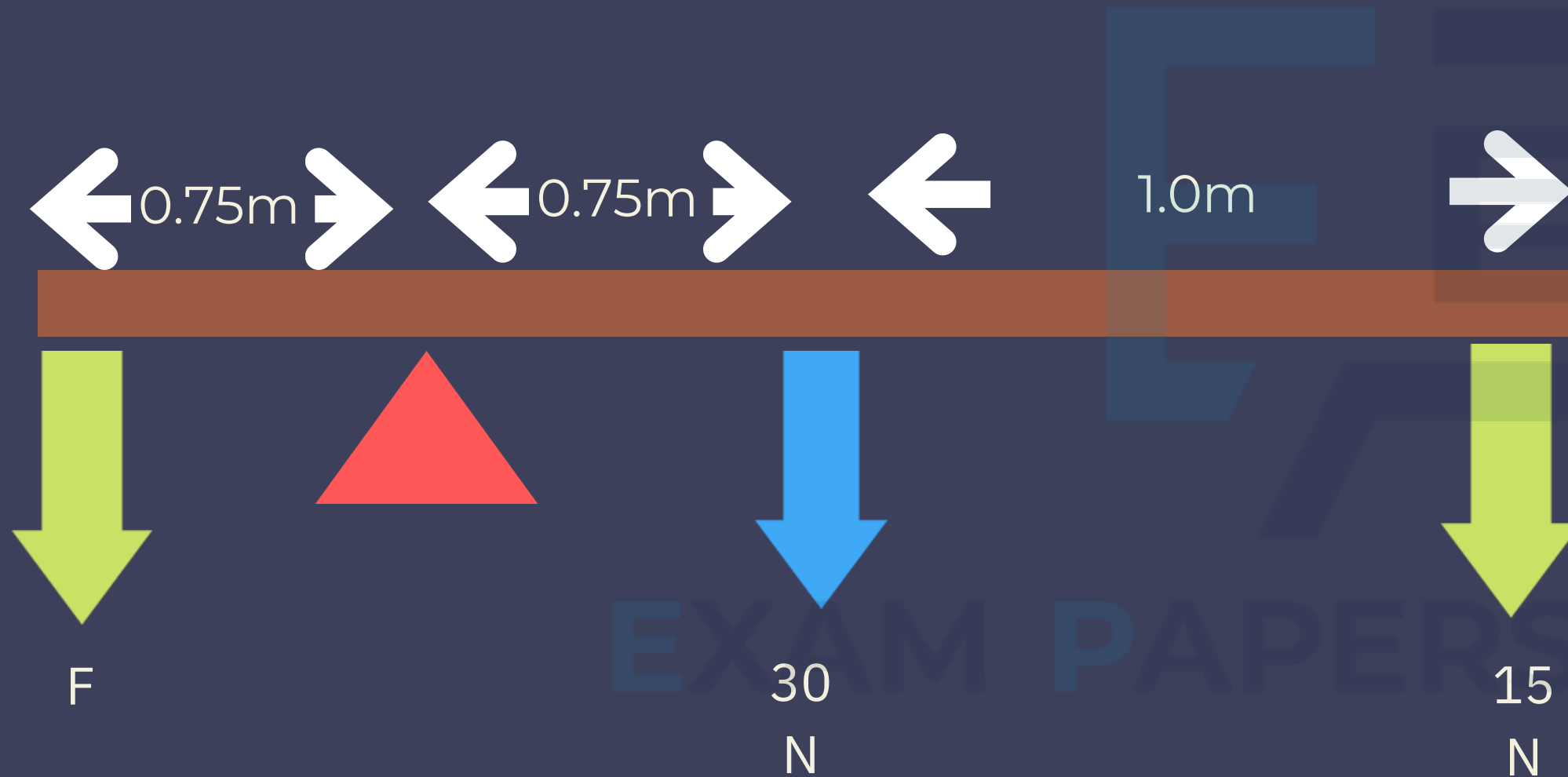

Solution

— “ —

Clockwise moment
 $= (30\text{N} \times 0.75) + (15\text{N} \times 1.75)$
 $= 48.75\text{n}$

Anticlockwise moment
 $= 0.75 \times f = 0.75 F$

$\text{CW} = \text{ACW}$

$0.75 f = 48.75$

$f = 65\text{N}$

— ” —

Equilibrium

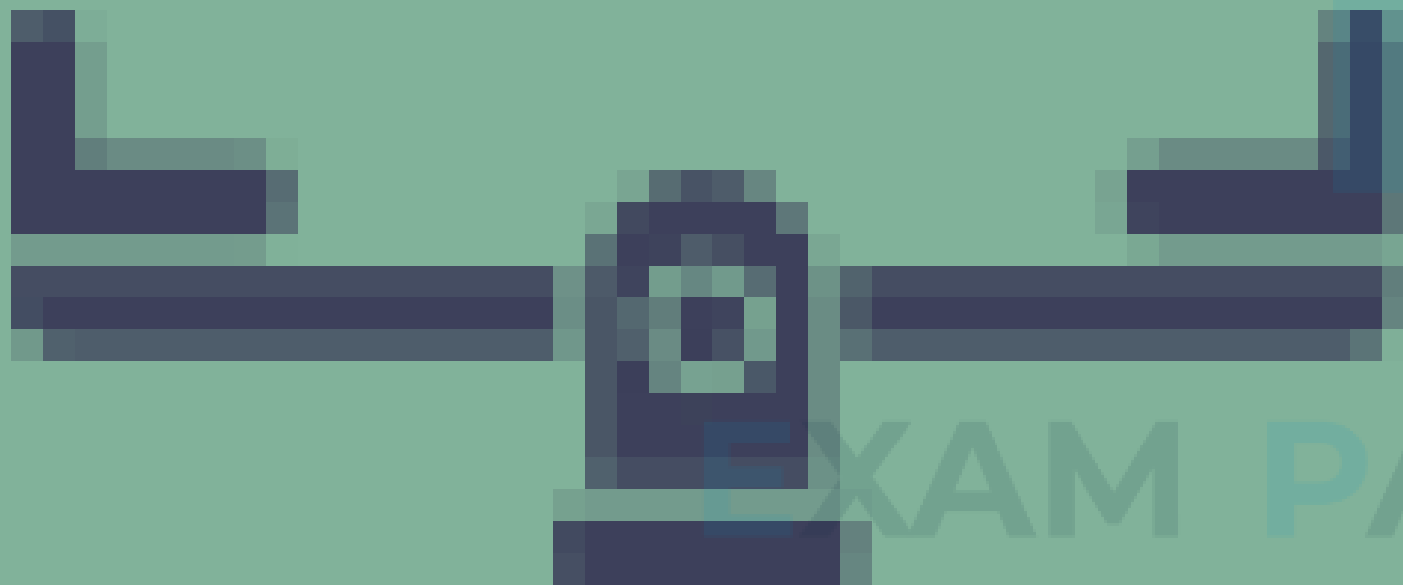

For an object in equilibrium, the total clockwise moment and total anticlockwise moment must equal (see Worked Example 2 and 3). The second condition is that the force must also be equal (downward force = upward force).

Worked Example

Question

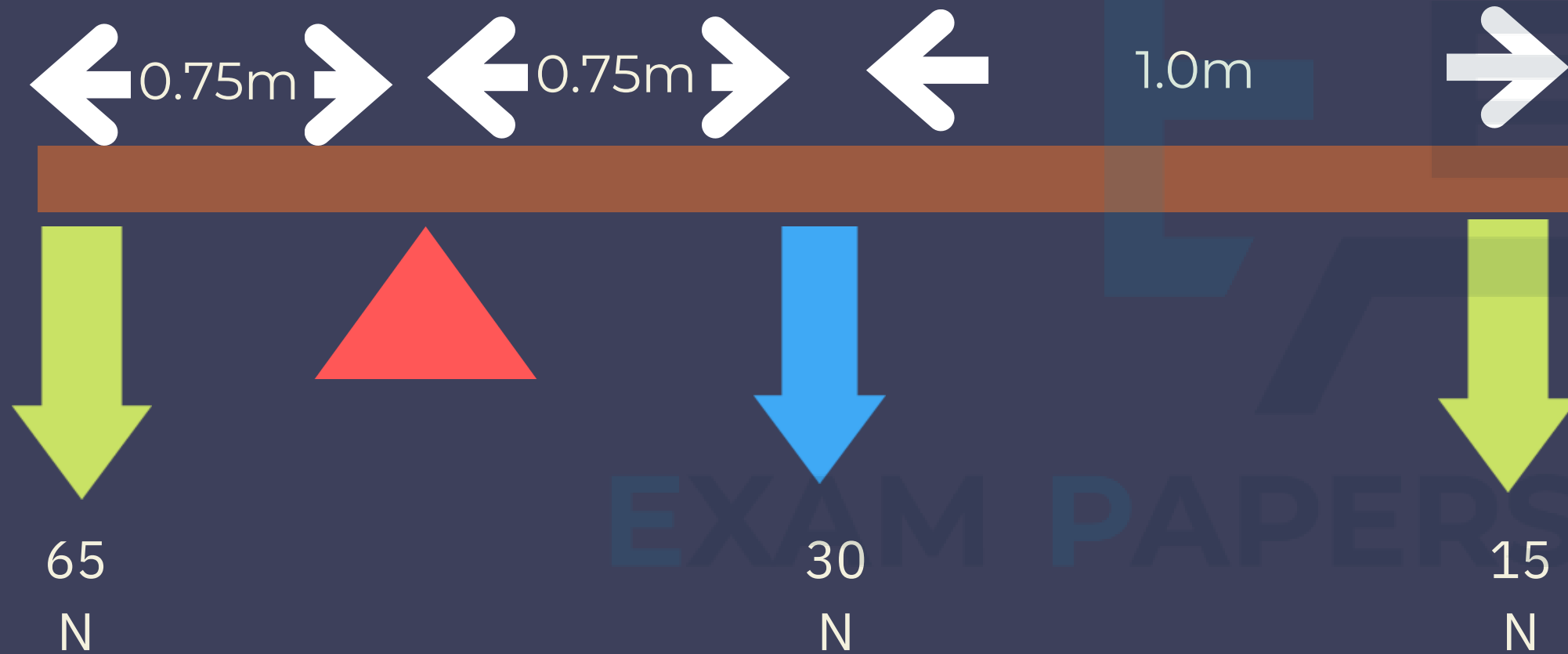

“
Using the answers from the previous worked example, measure the total downward force.”

Worked Example

Question

“

Using the answers from the previous worked example, measure the total downward force.

Answer = 110N

”

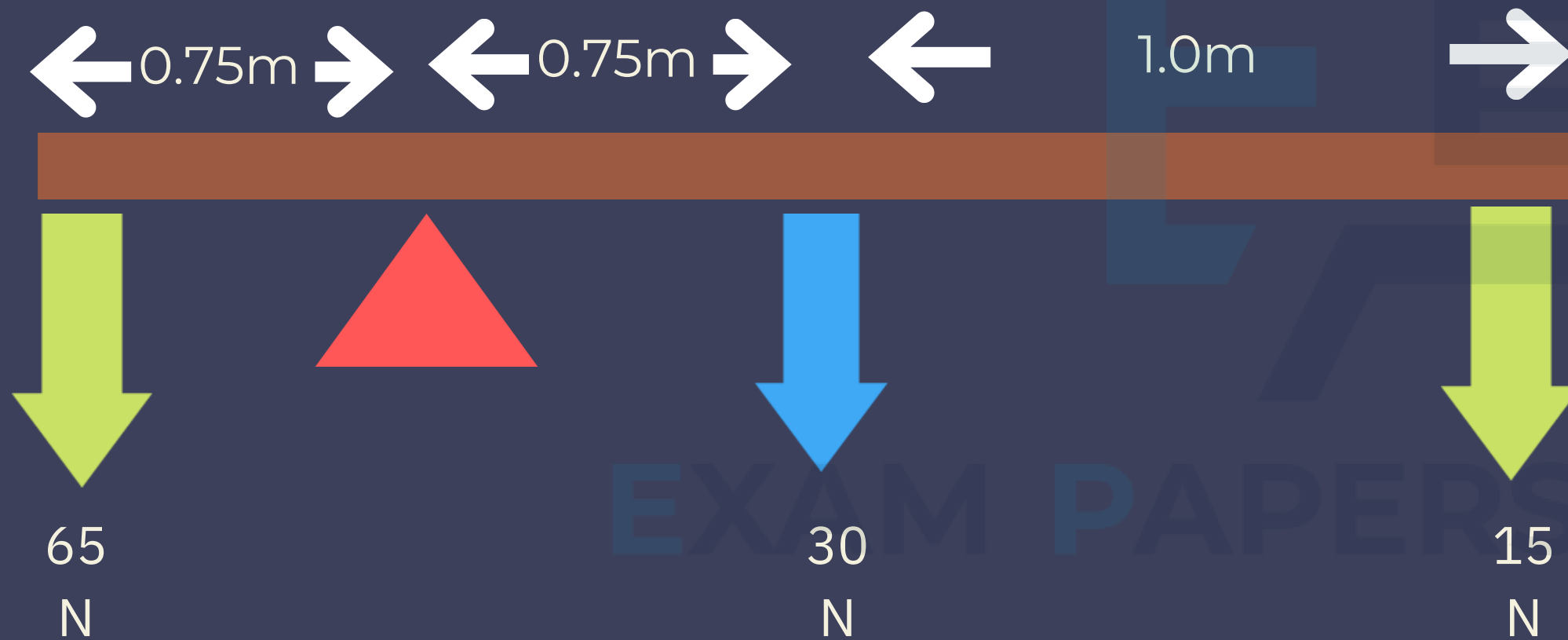

Worked Example

Question

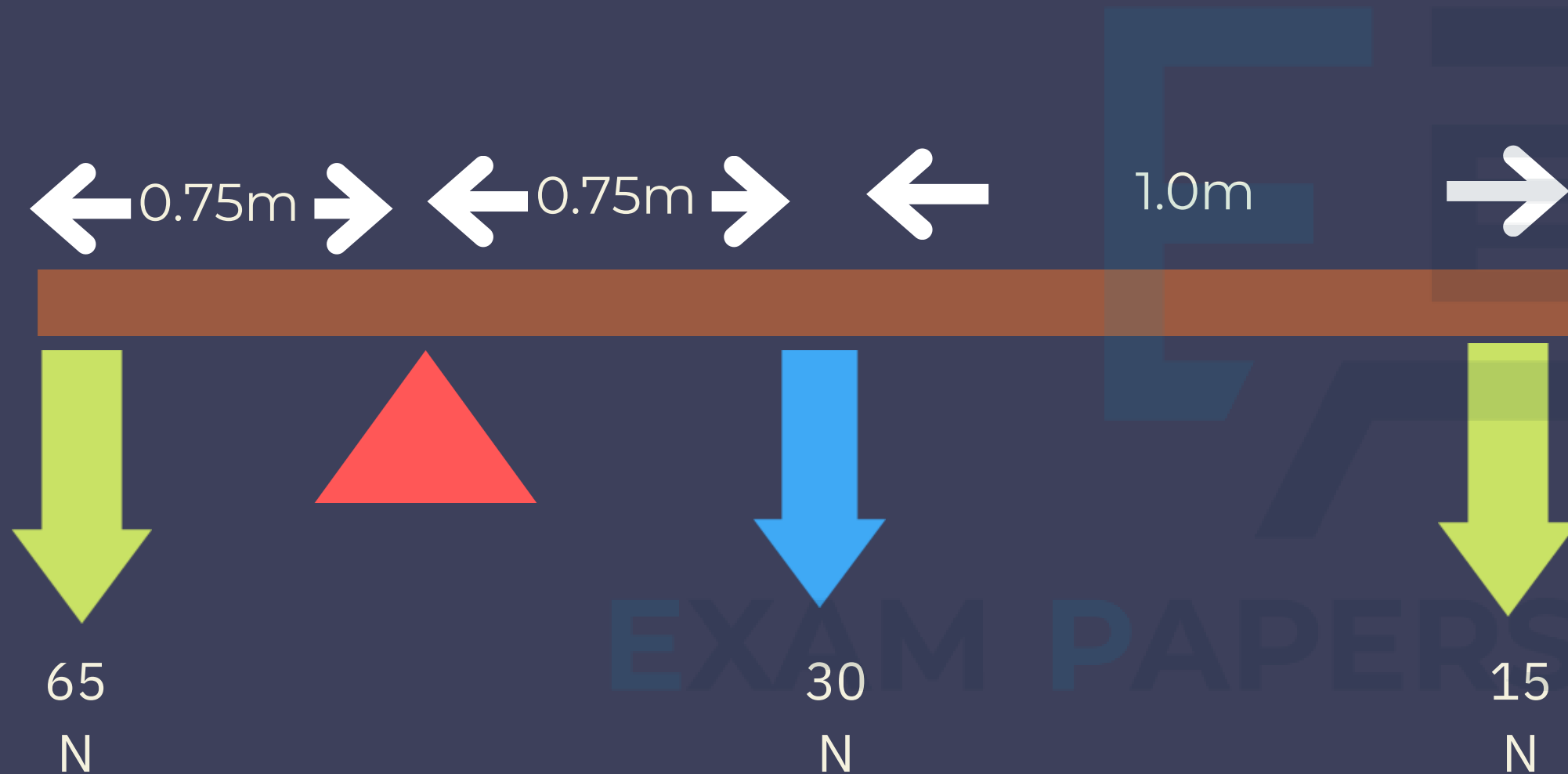

Mark the upward contact force with the letter R on the diagram above (hint: Pivot).

B. State the upward contact force.

Worked Example

Question

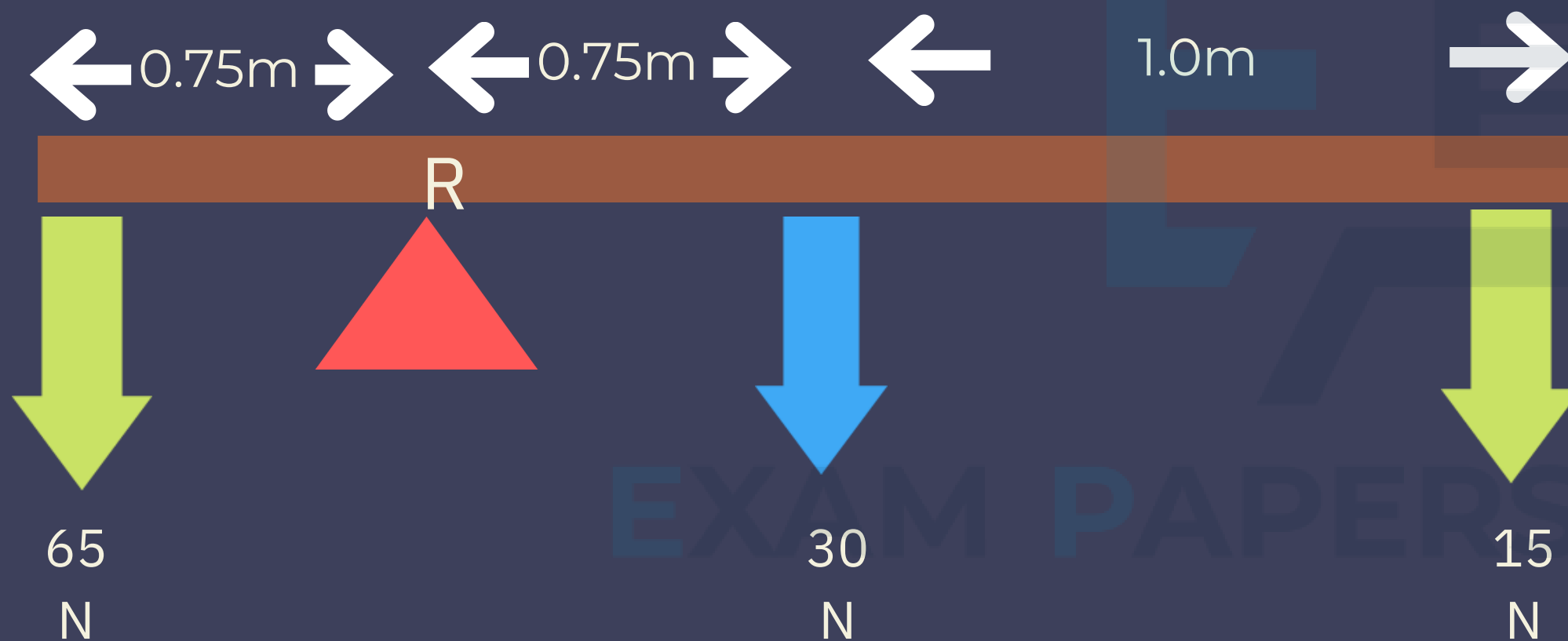

Mark the upward contact force with the letter R on the diagram above (hint: Pivot).

B. State the upward contact force.

Answer = 110 N

Worked Example

Question

— “ —————

- Determine the position to the right of the pivot where the 200N load should be placed for the ruler to achieve balance.
 - Find the force exerted on the pivot due to the load.
- ”

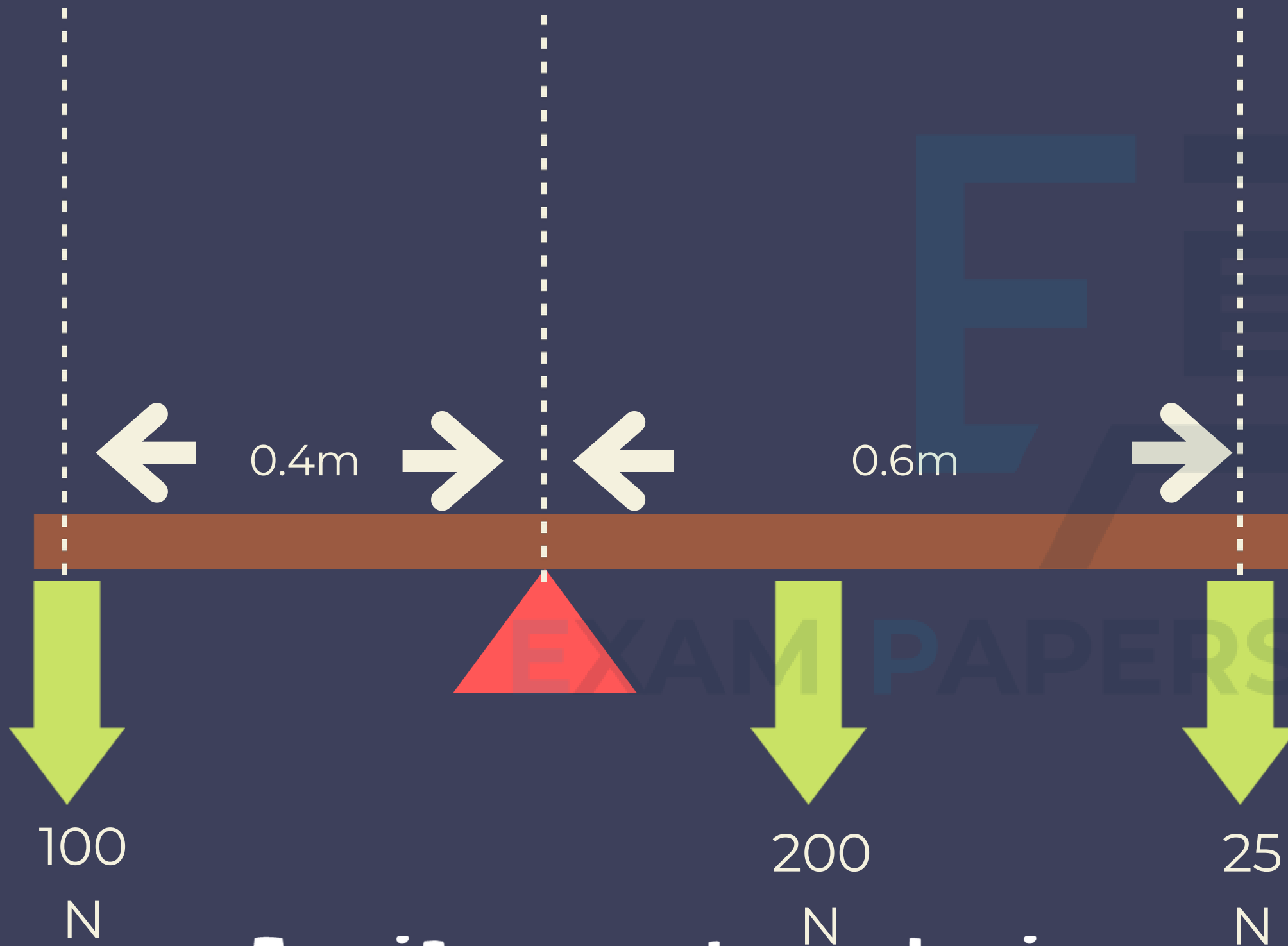

A uniform metre ruler is balanced at its centre.

Worked Example

Solution (a)

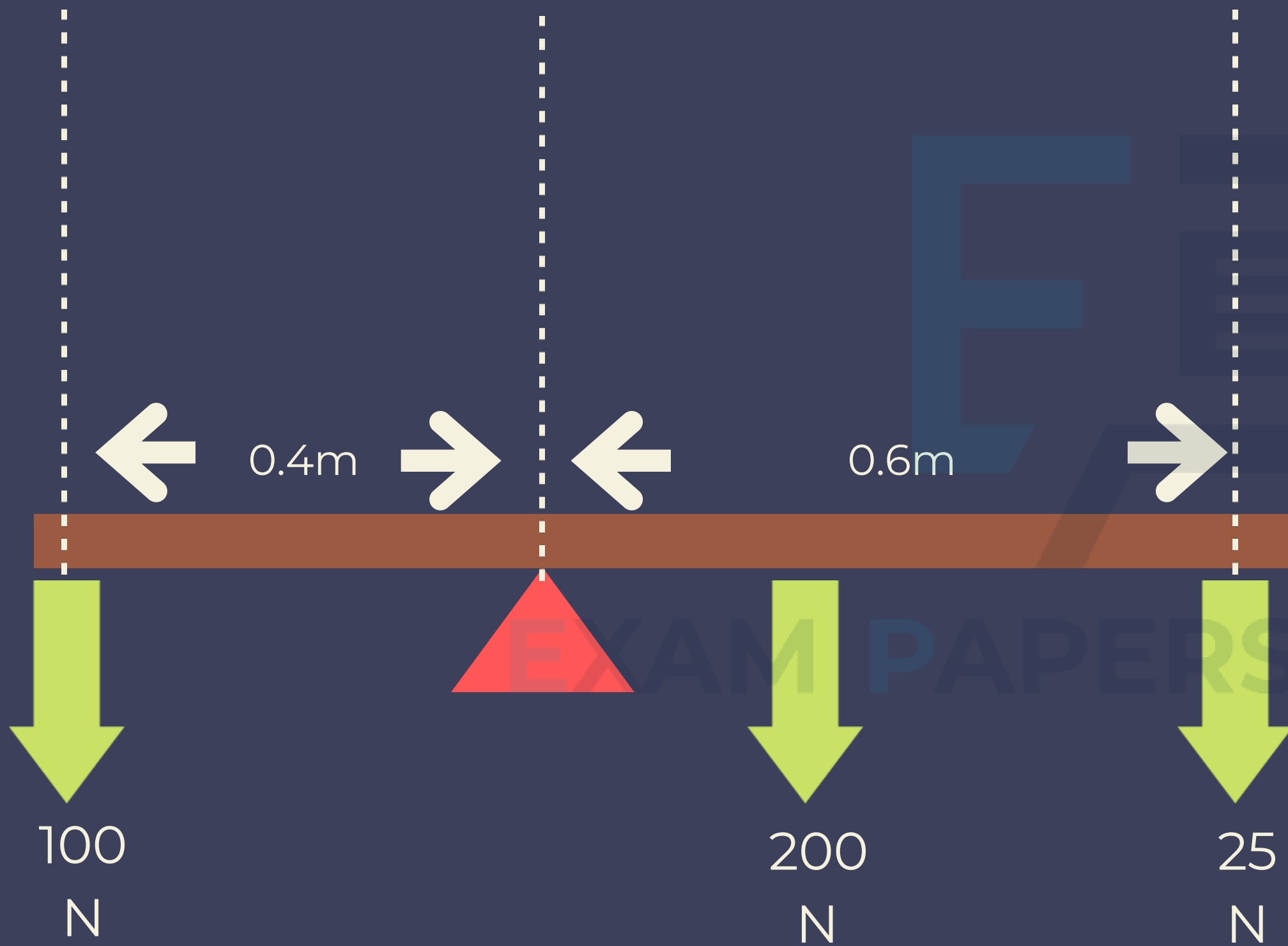

— “ —
Anticlockwise moment

clockwise moment

— ” —

Worked Example

Solution (a)

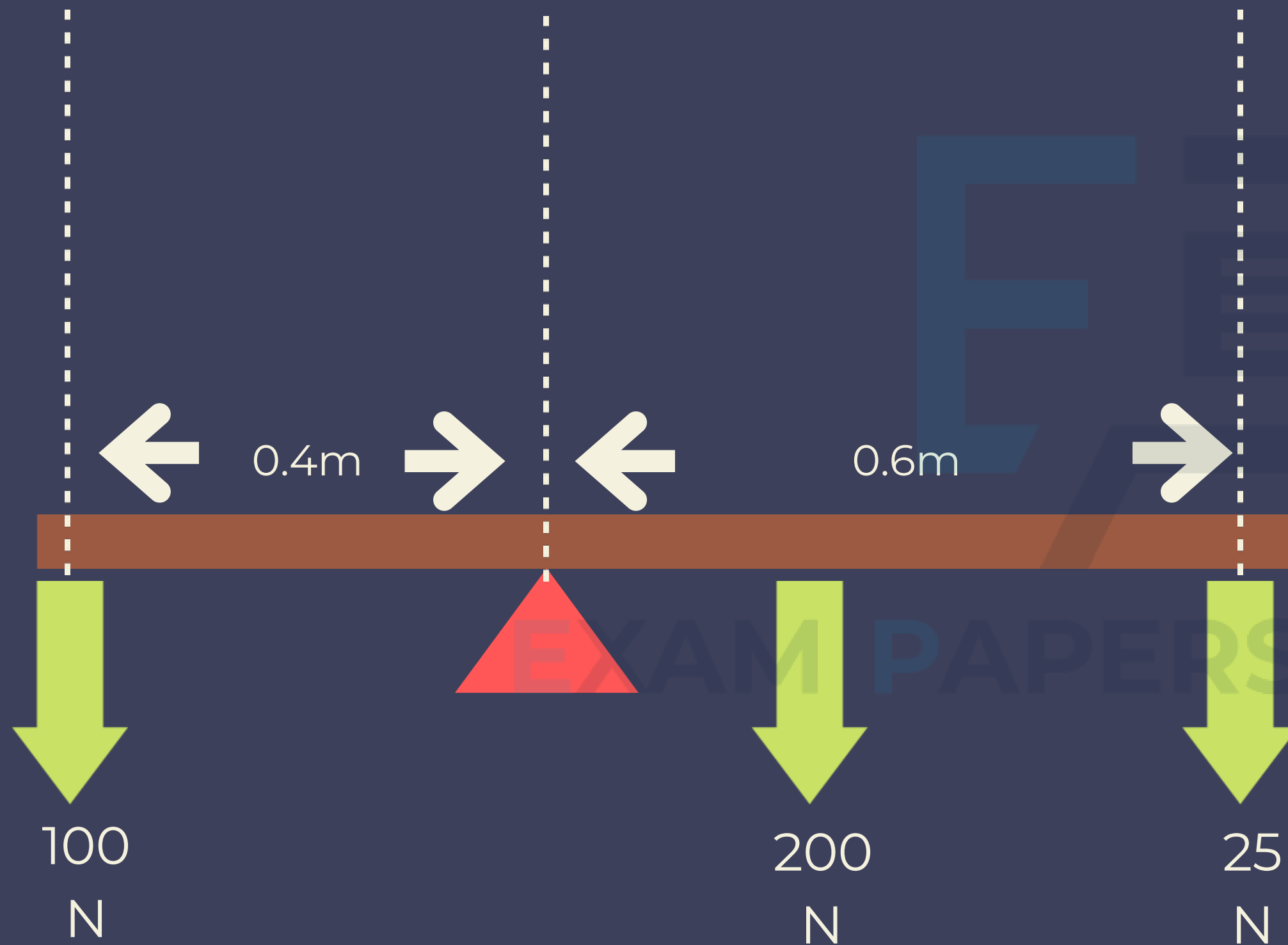

— “ —

Anticlockwise moment
 $= 100\text{N} \times 0.4\text{m}$
 $= 40\text{ nm}$

clockwise moment
 $= (25\text{n} \times 0.6\text{M}) + (200\text{N} \times l)$
 $= 15\text{nm} + 200l$

$Cw = acw$
 $15\text{nm} + 200l = 40\text{nm}$
 $200 L = 25 \text{ NM}$
 $l = 25 / 200 = 0.125 \text{ m}$ ” —

Worked Example

Solution (b)

— “ —
Upward force = downward force

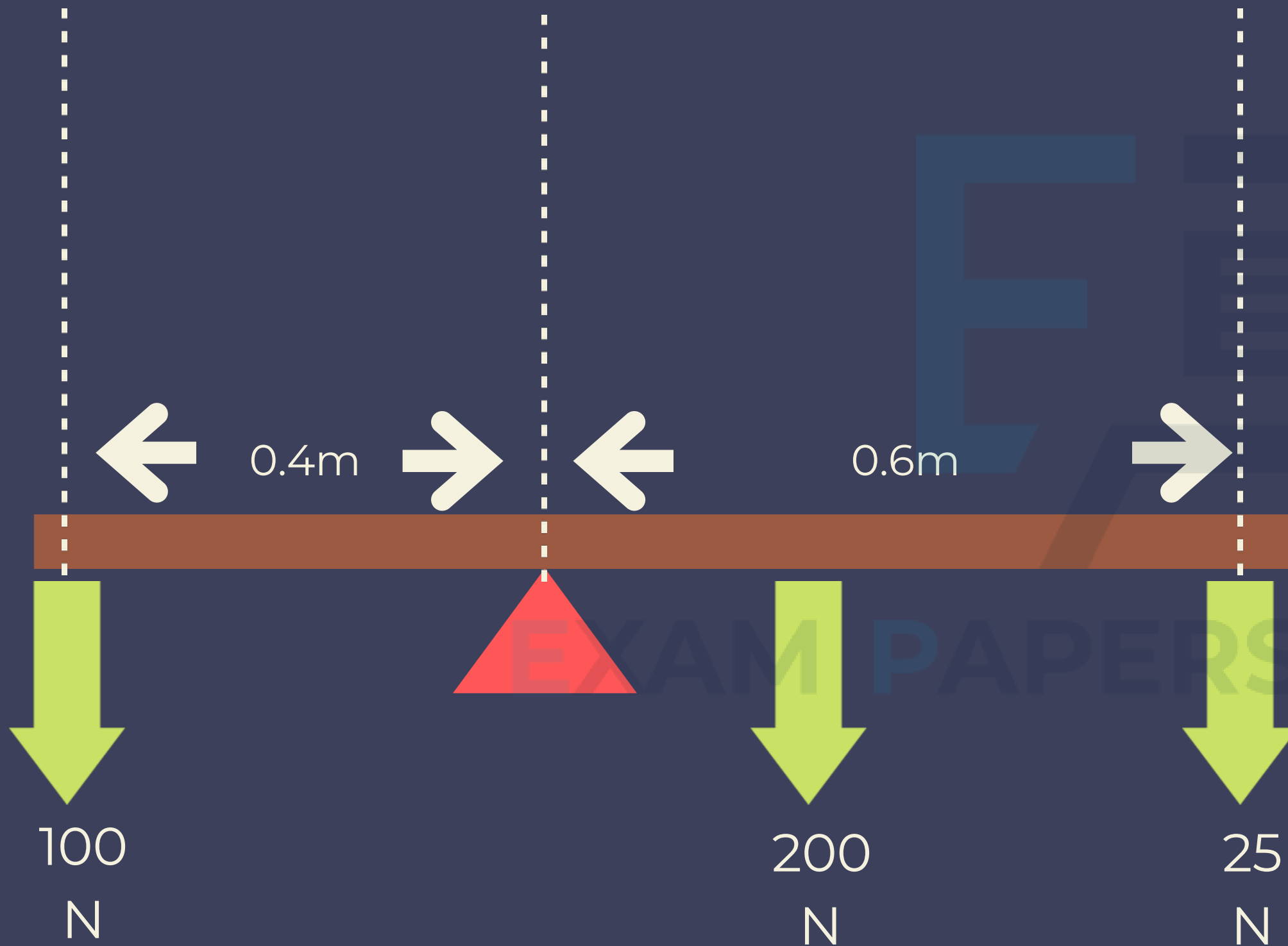

— ” —

Worked Example

Solution (b)

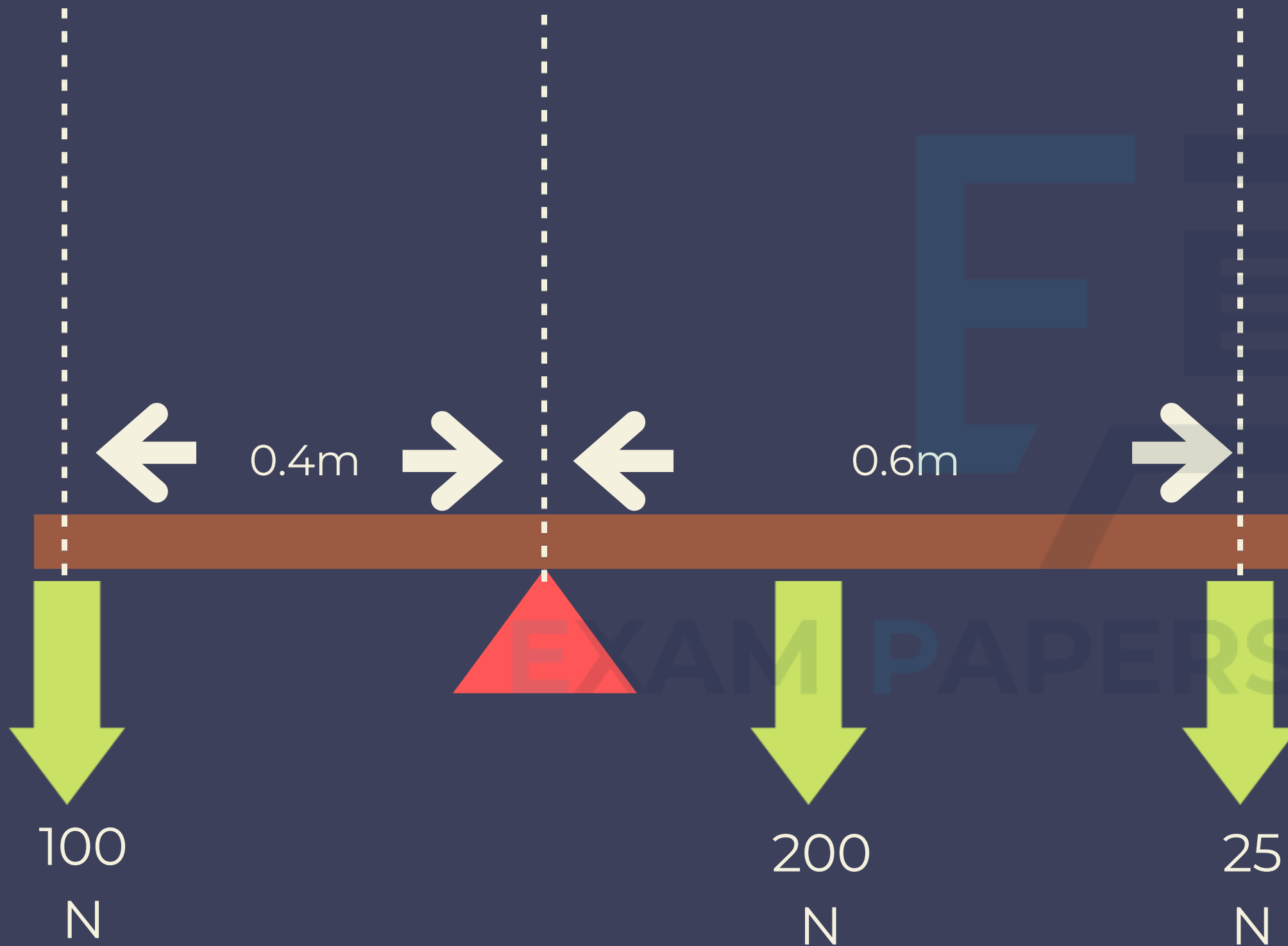

— “ —
Upward force = downward force

$$100\text{N} + 200\text{N} + 25\text{N} \\ = 325\text{n}$$

— ” —

DEFINITION

The center of gravity is the point where an object's weight can be considered to be concentrated, balancing evenly in all directions.

Centre of gravity

The images below show The position of the centre of gravity for different objects. Symmetry can help to judge where the centre of gravity lies.

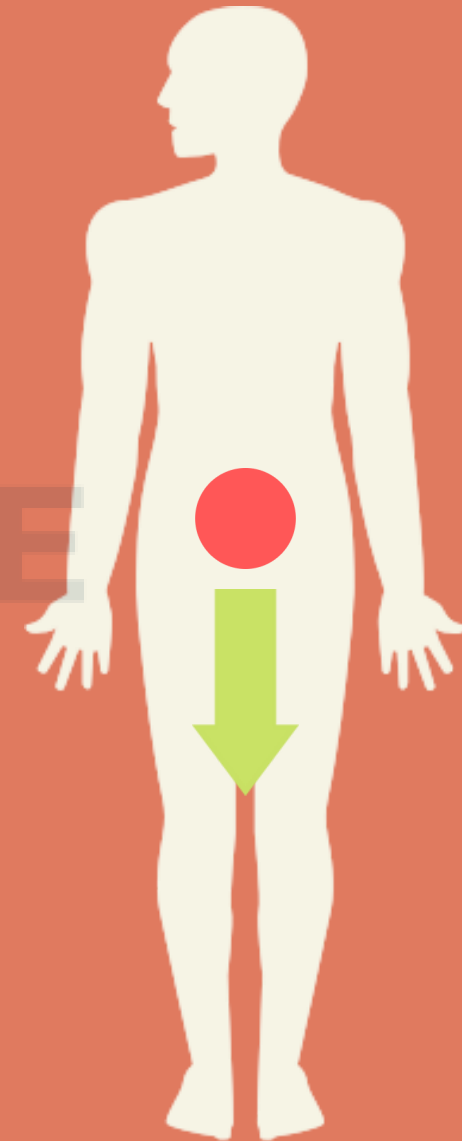
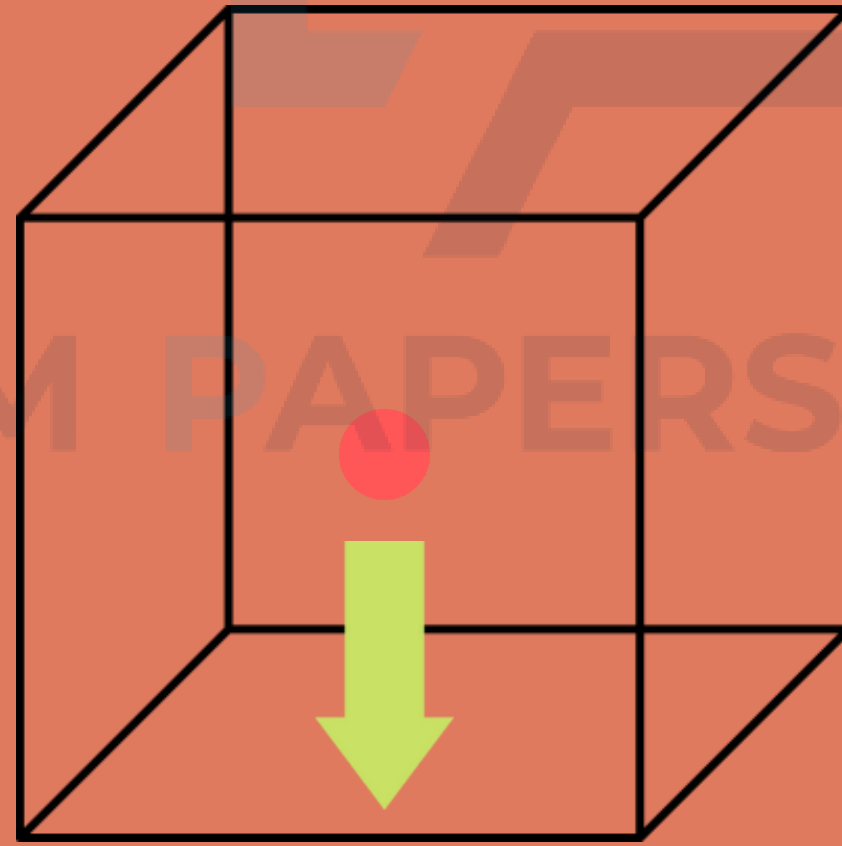
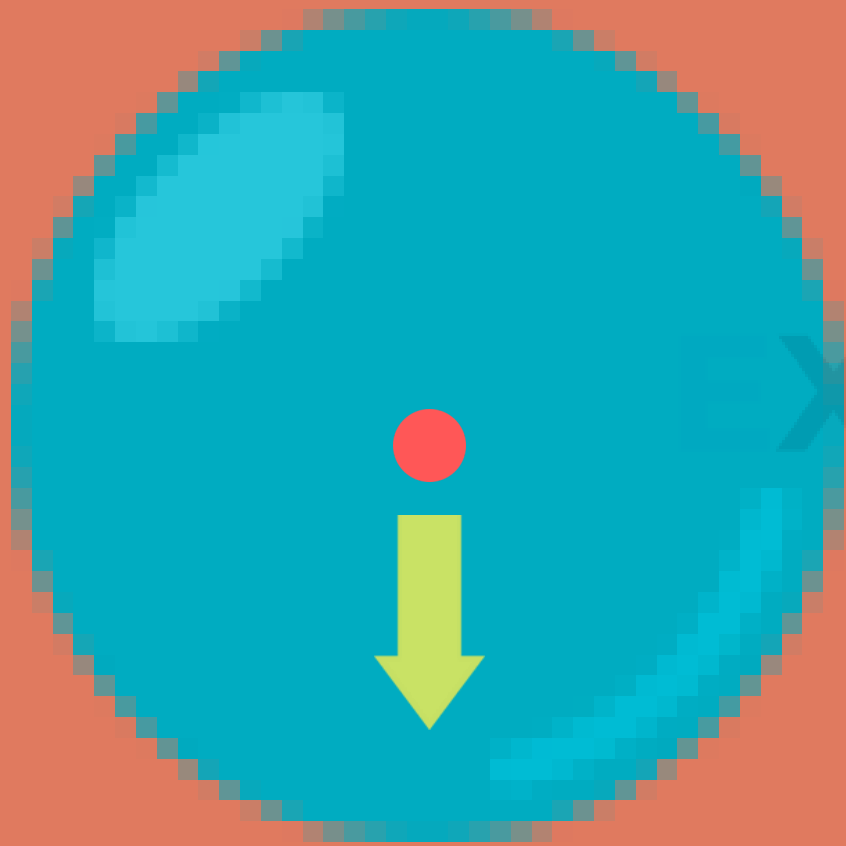

Centre of gravity

Finding the centre of gravity for irregular shape

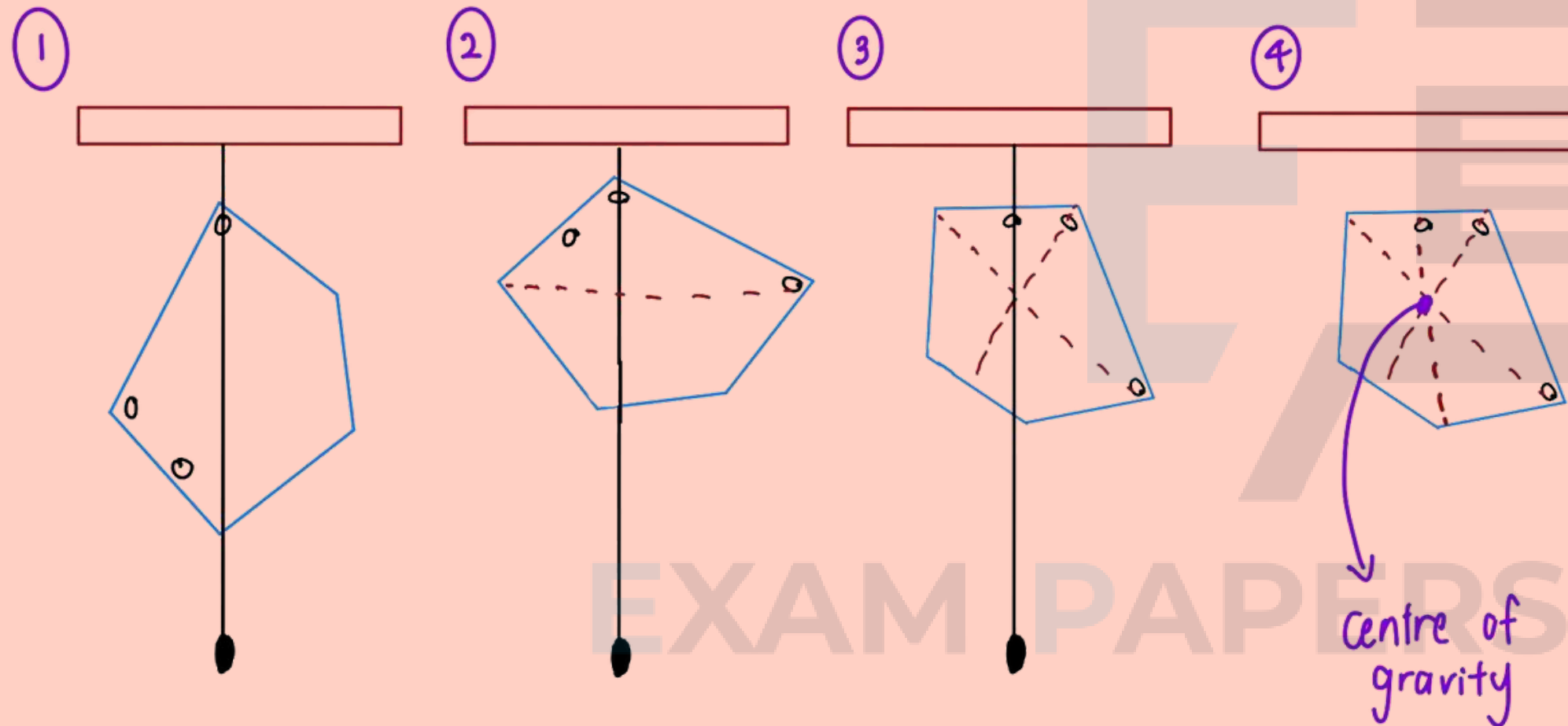

1. Take a sheet with three holes near its edge, then suspend the sheet through each hole one by one.
2. Draw an equilibrium line for each suspension point.
3. The point where these three lines intersect is the centre of gravity.

Relationship between Centre of Gravity and Stability

Tall glass Example

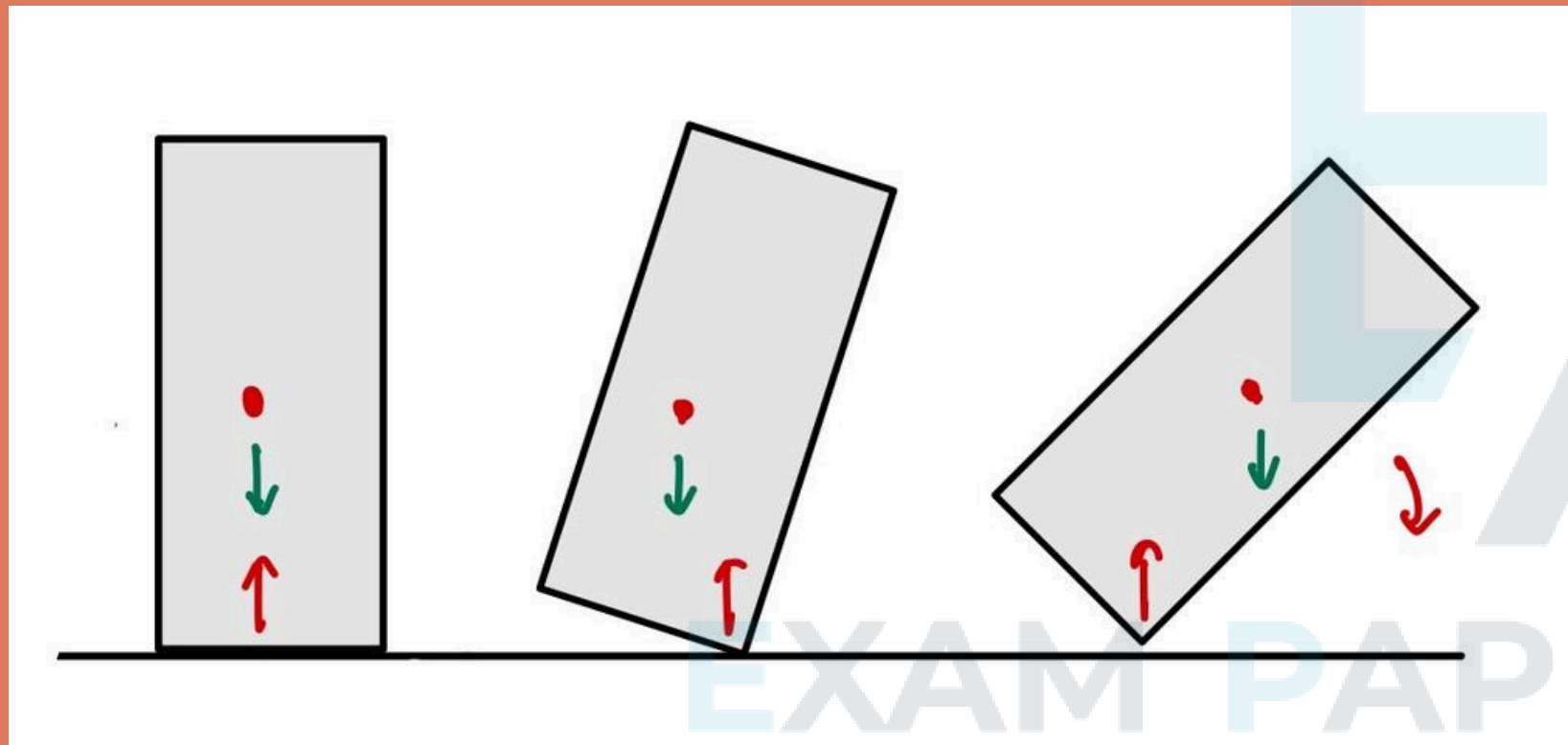

In the left image, the glass stands upright with its weight downward and the table's upward contact force **aligns**, resulting in **equilibrium**.

In the middle image, the glass tilts slightly **right**, causing the forces to no longer align. A pivot forms where the glass touches the table base. The weight line of the glass lies left of this pivot, creating a counterclockwise moment that tends to return the glass to an upright position.

In the right image, the glass tips further. Its weight now acts **right** of the pivot, generating a **clockwise moment** that causes the glass to tip completely to the right.

The diagram shows a tower crane being used to lift a heavy load. In order to maintain equilibrium, the tower crane has a counterweight W on the right hand side.

The weight of the boom (crane arm) can be ignored in this question.

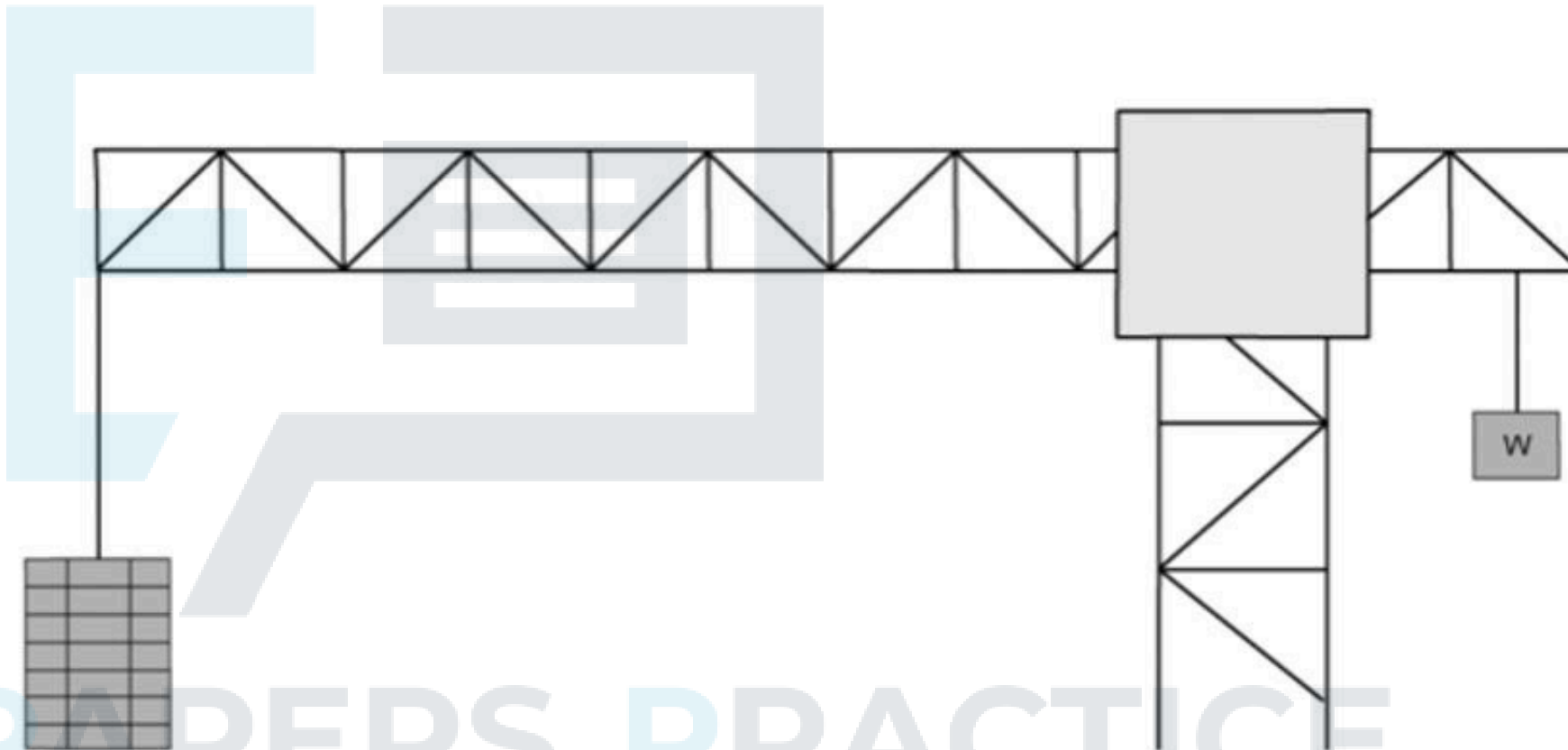

What is the weight of the load being lifted?

- A Greater than W
- B Less than W
- C The same as W
- D There is insufficient information in the question to tell.

The diagram shows a tower crane being used to lift a heavy load. In order to maintain equilibrium, the tower crane has a counterweight W on the right hand side.

The weight of the boom (crane arm) can be ignored in this question.

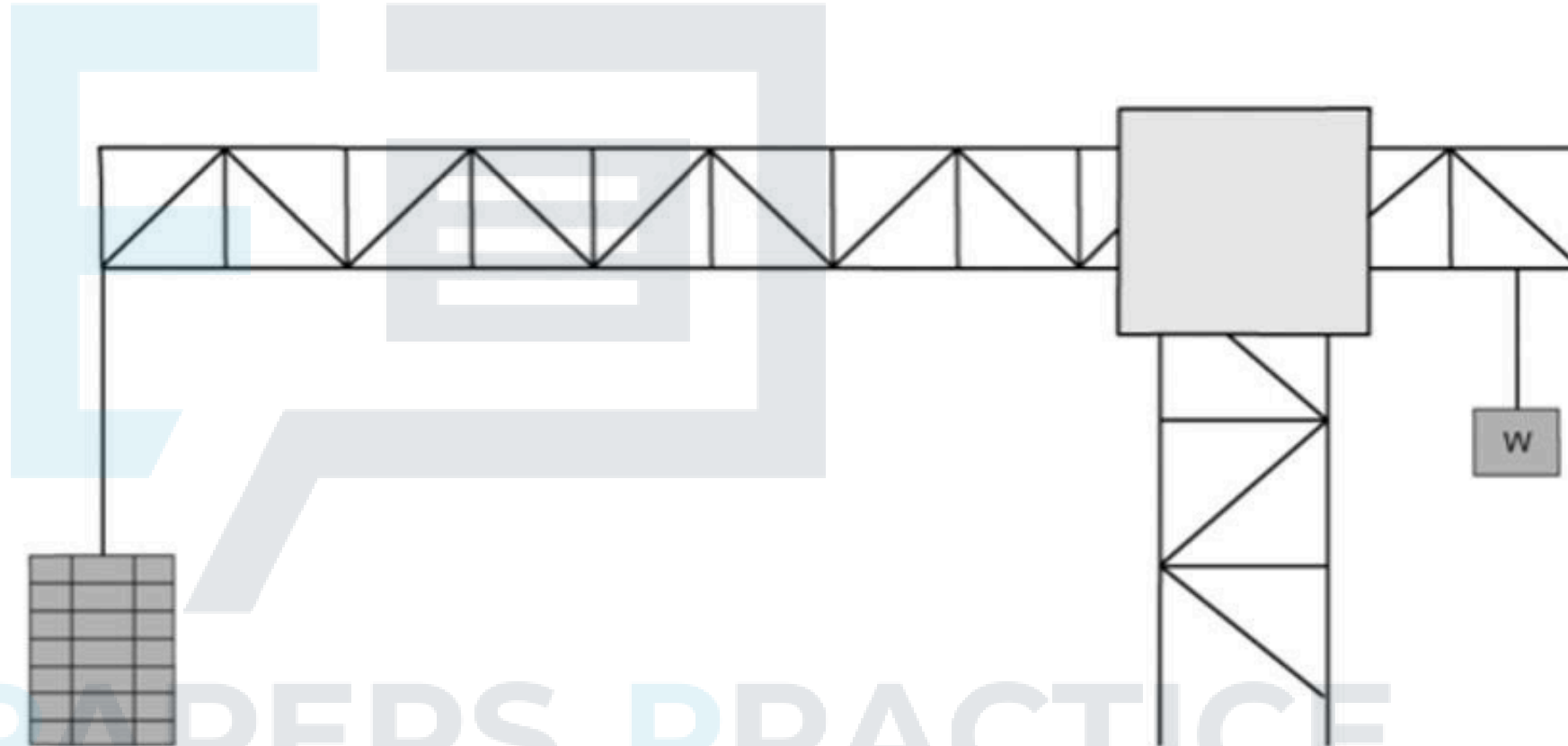

What is the weight of the load being lifted?

- A Greater than W
- B Less than W
- C The same as W
- D There is insufficient information in the question to tell.

A cardboard rectangle is hung from a nail as shown in the diagram.

A plumb line is also hung from the nail.

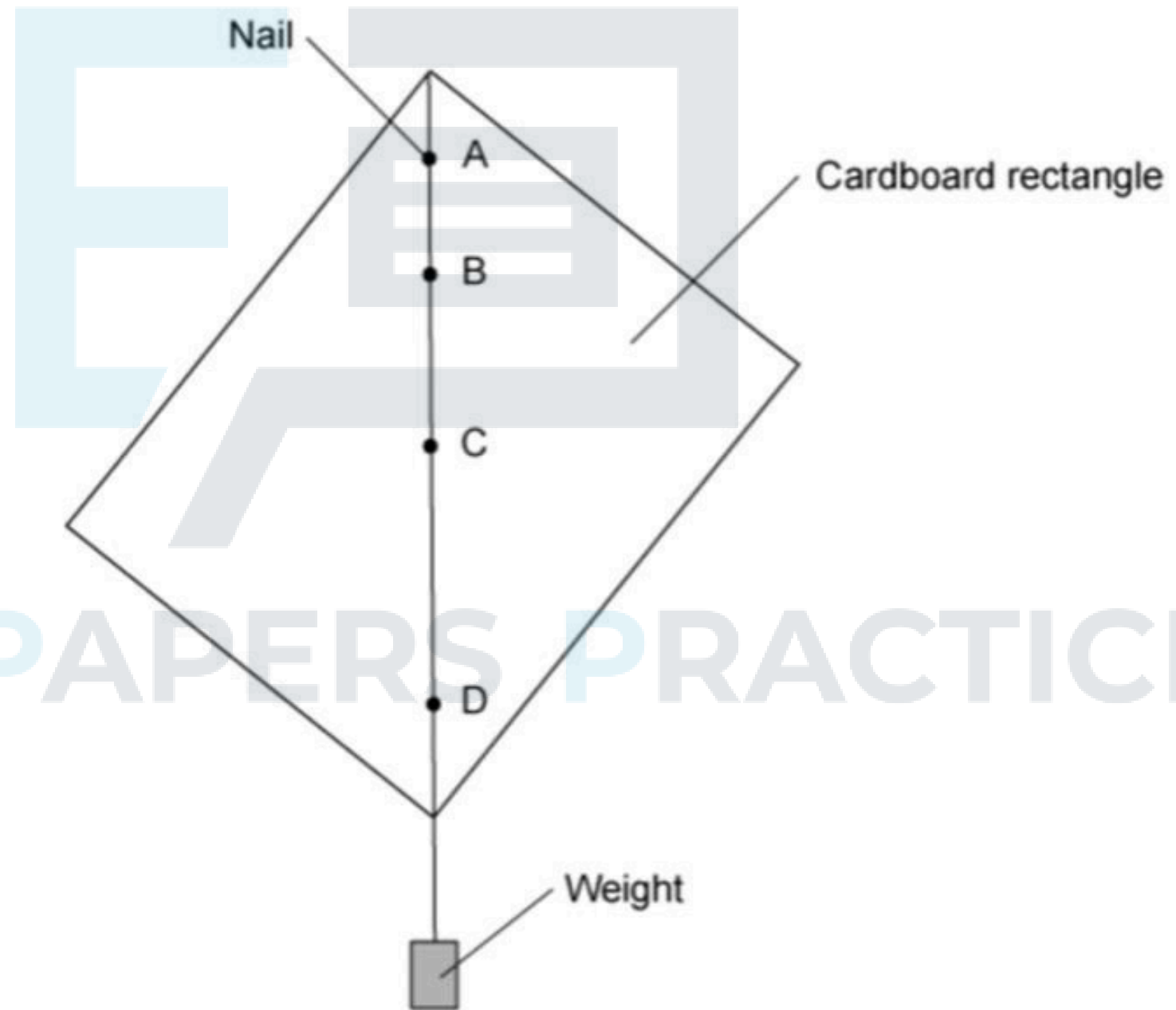

Which of the points labelled is the centre of mass of the cardboard rectangle?

A cardboard rectangle is hung from a nail as shown in the diagram.

A plumb line is also hung from the nail.

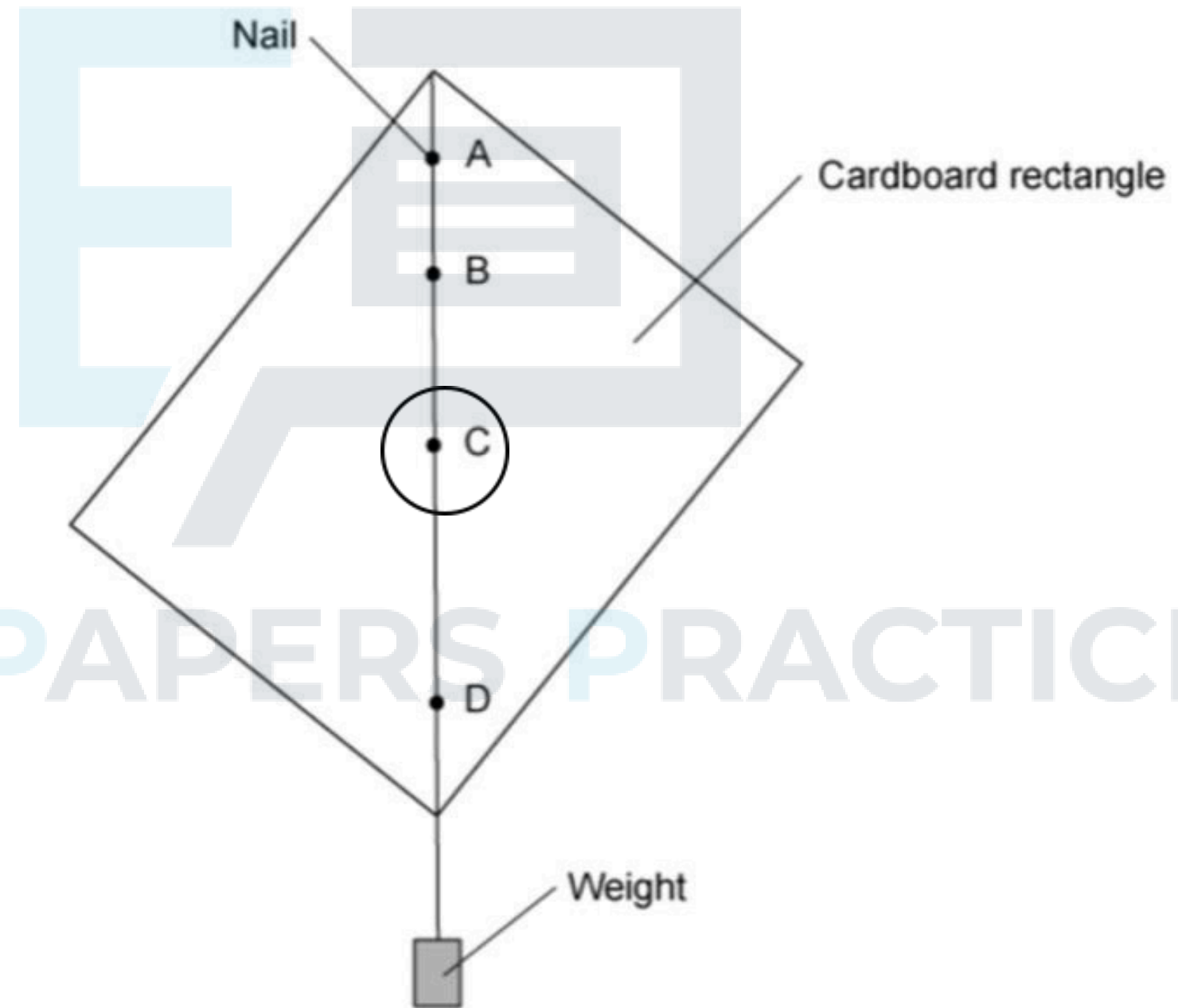

Which of the points labelled is the centre of mass of the cardboard rectangle?

A wardrobe is shown tilted at a variety of angles.

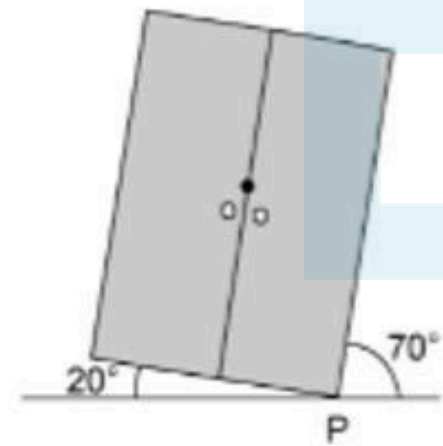

A

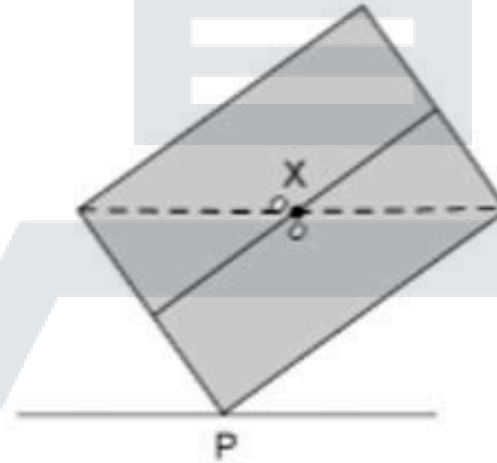

B

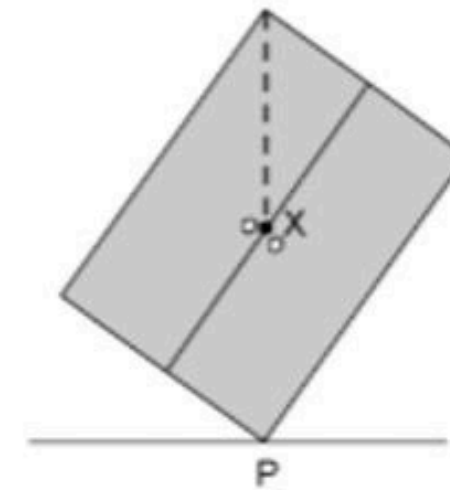

C

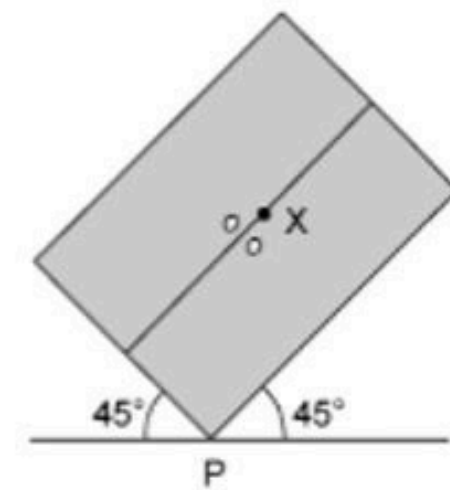

D

In which position is the wardrobe in equilibrium?

A wardrobe is shown tilted at a variety of angles.

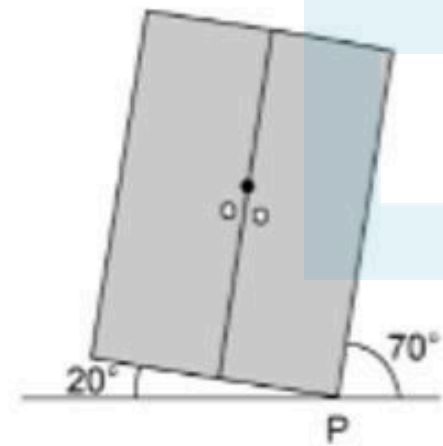

A

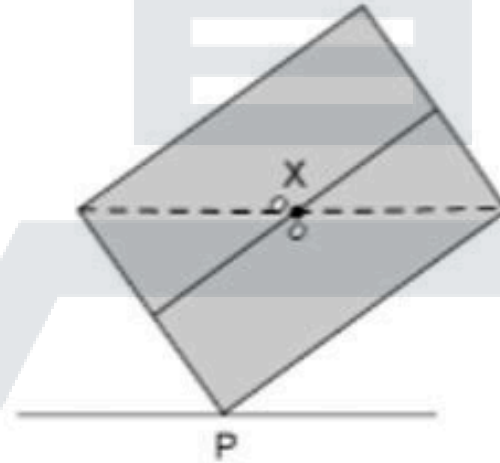

B

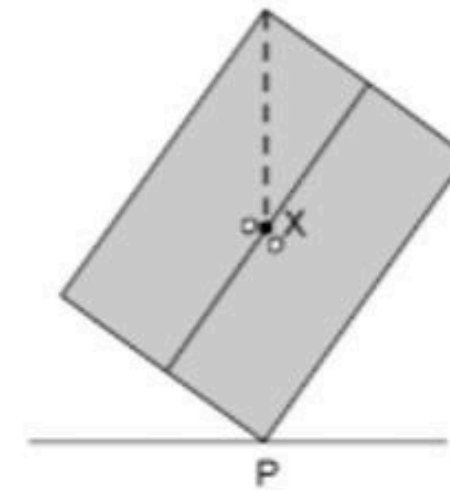

C

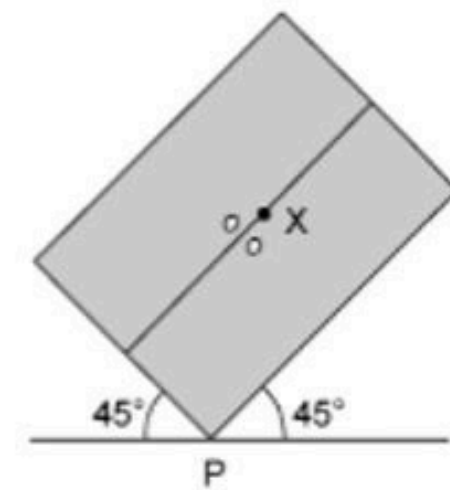

D

In which position is the wardrobe in equilibrium?

The diagrams each show a beam resting on a pivot and being acted on by some forces. The beam is not attached to the pivot. The pivot is in the centre of the rod in each case.

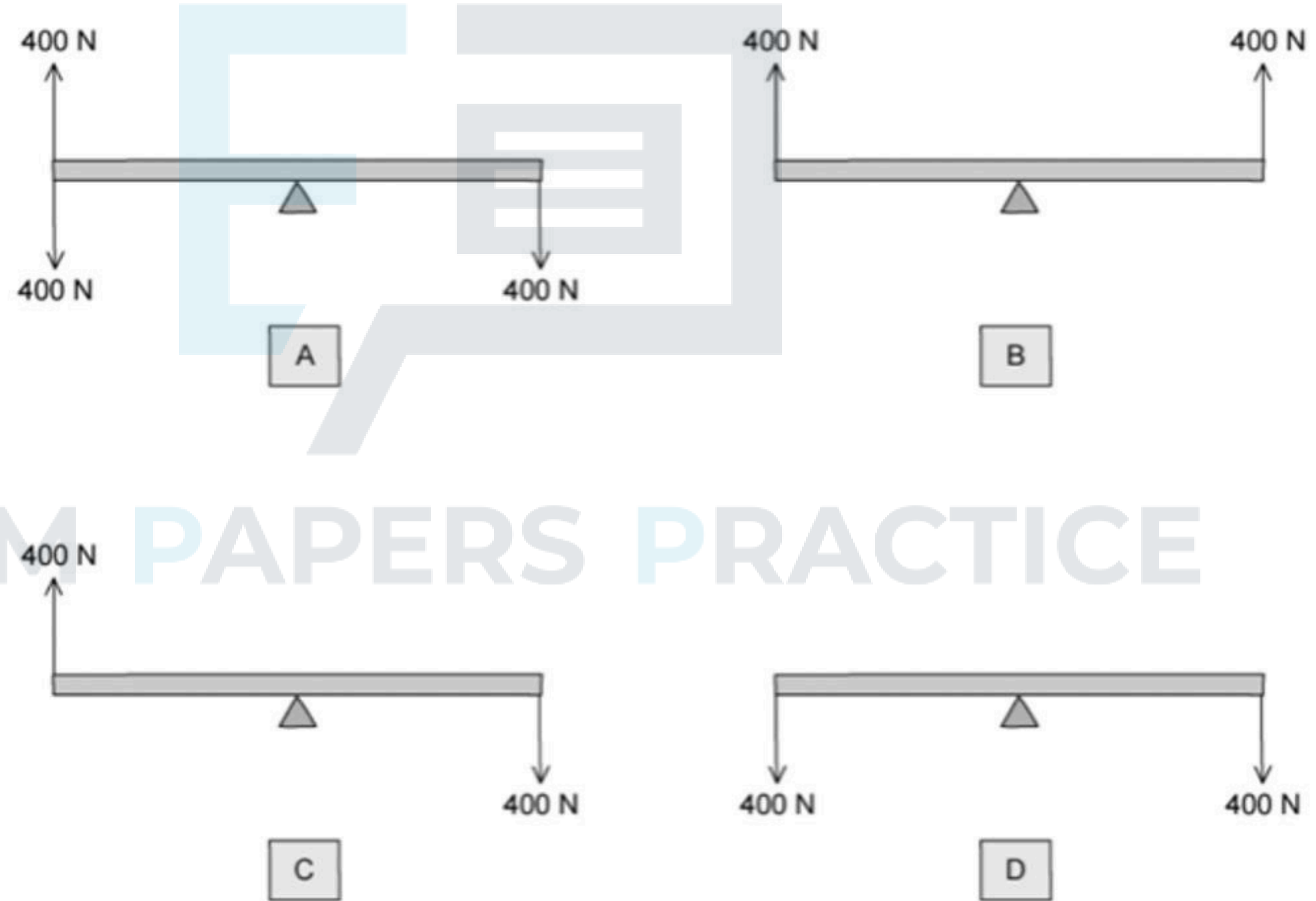

Which of the beams is in equilibrium?

The diagrams each show a beam resting on a pivot and being acted on by some forces. The beam is not attached to the pivot. The pivot is in the centre of the rod in each case.

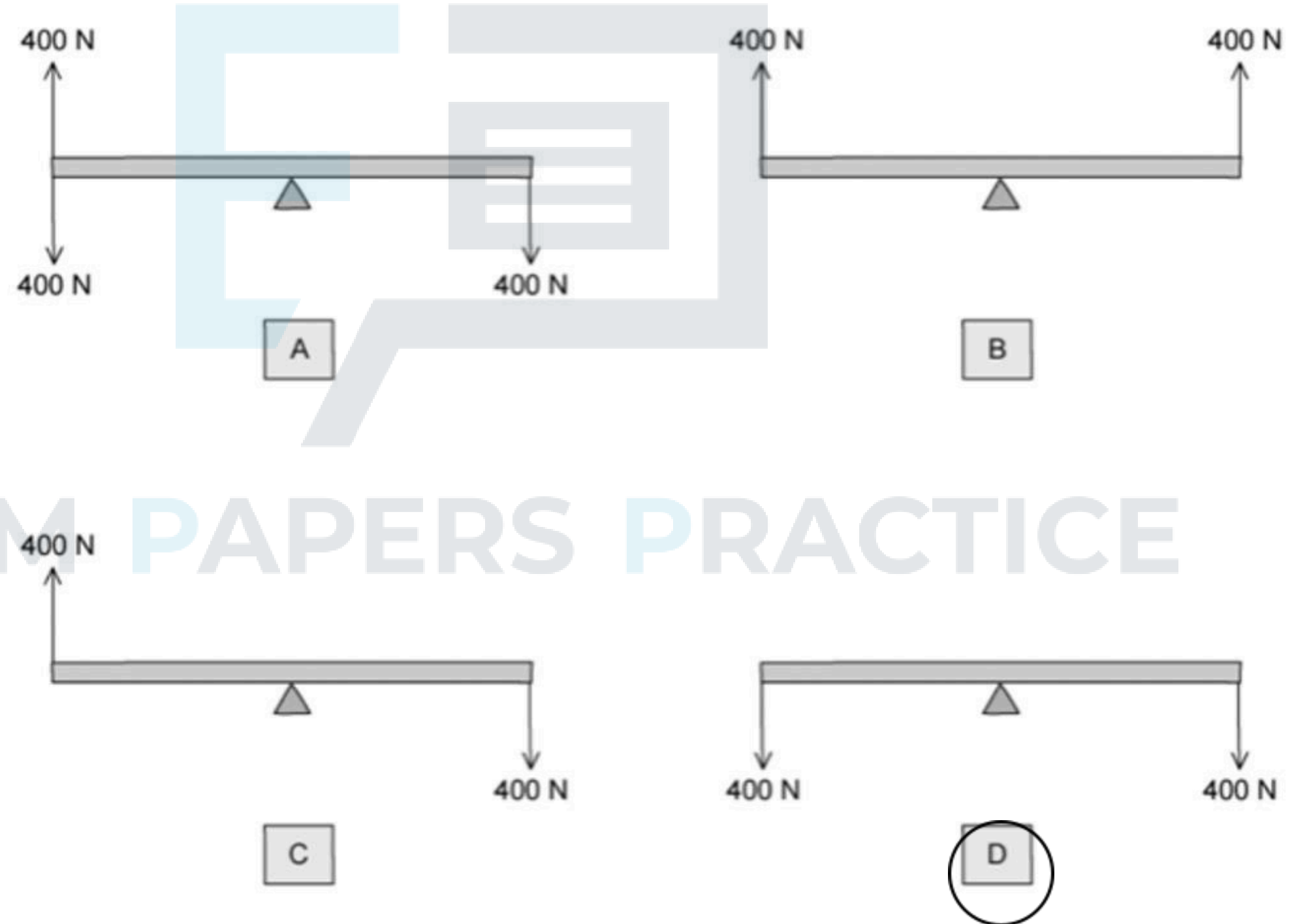

Which of the beams is in equilibrium?

A plank rests on two supports, as shown in the diagram. The plank is in equilibrium. Three forces act on the plank.

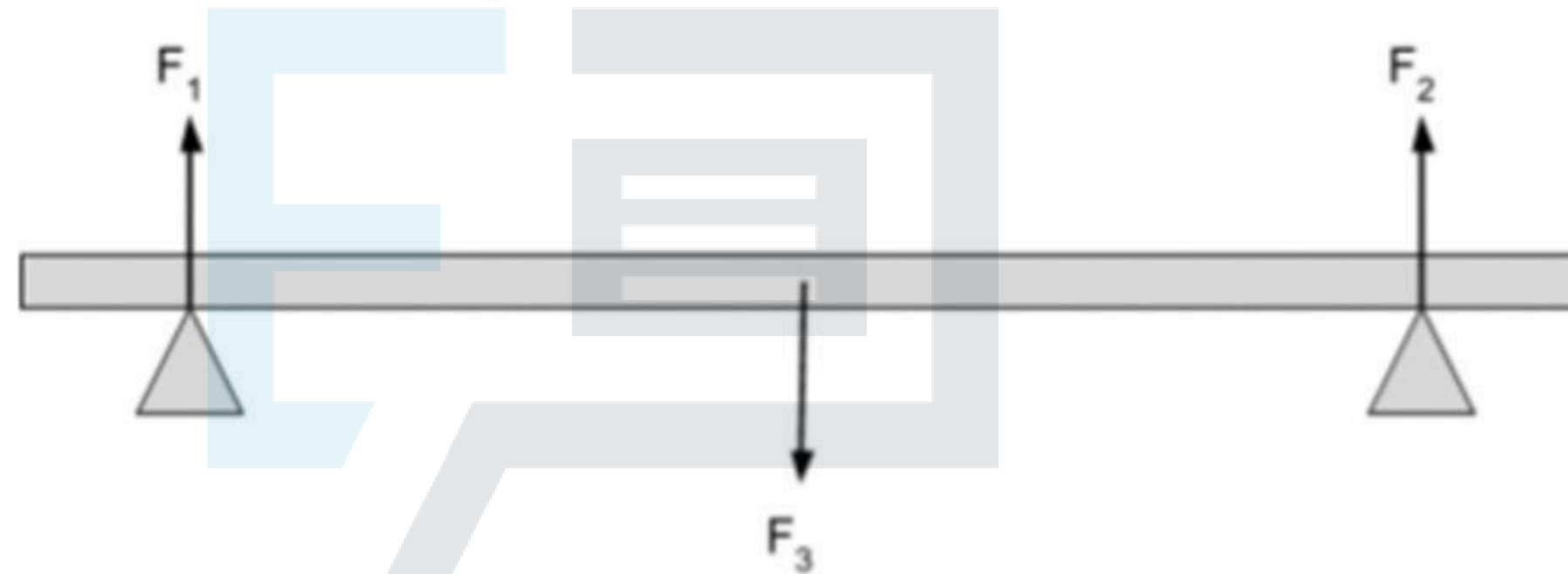

Which statement is true?

- A** The upward force is larger than the downward force.
- B** The resultant force on the beam is zero and the resultant moment on the beam is zero.
- C** The resultant moment on the beam is zero, but the resultant force is not zero.
- D** All three forces are equal in size.

A plank rests on two supports, as shown in the diagram. The plank is in equilibrium. Three forces act on the plank.

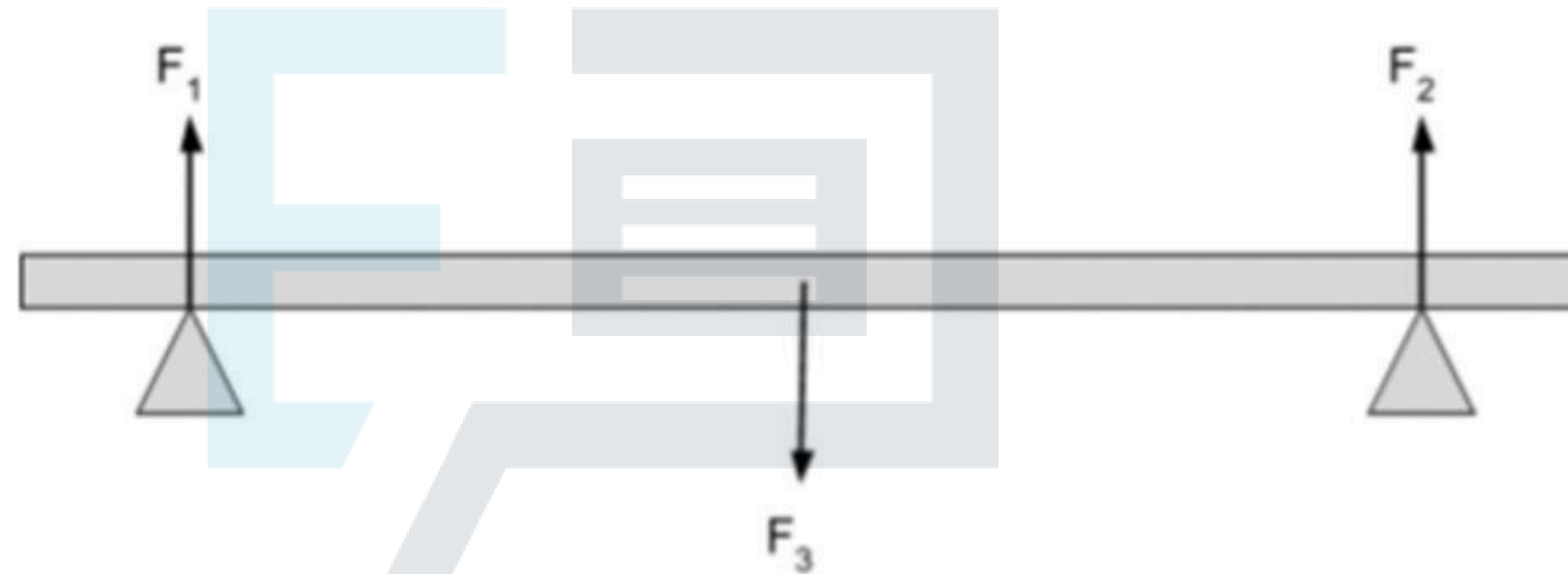

Which statement is true?

- A The upward force is larger than the downward force.
- B The resultant force on the beam is zero and the resultant moment on the beam is zero.
- C The resultant moment on the beam is zero, but the resultant force is not zero.
- D All three forces are equal in size.

1 The diagram shows a uniform metre rule PQ in equilibrium.

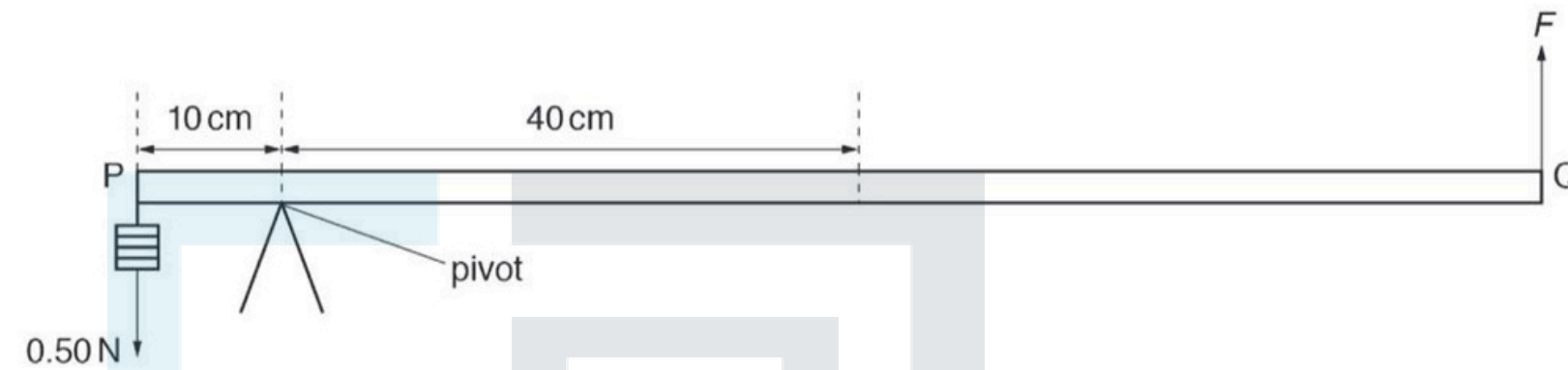

The distance PQ is 100 cm. The mass of the metre rule is 0.12 kg and its weight is W .

(a) On the diagram, draw and label:

1. an arrow to show the force W acting on PQ at the centre of mass
2. an arrow to show the force R acting on PQ at the pivot.

[2]

(b) By taking moments about the pivot, calculate F .

$F = \dots\dots\dots$ [4]

(c) Calculate R .

For more help, please visit www.exampaperspractice.co.uk [2]

1 The diagram shows a uniform metre rule PQ in equilibrium.

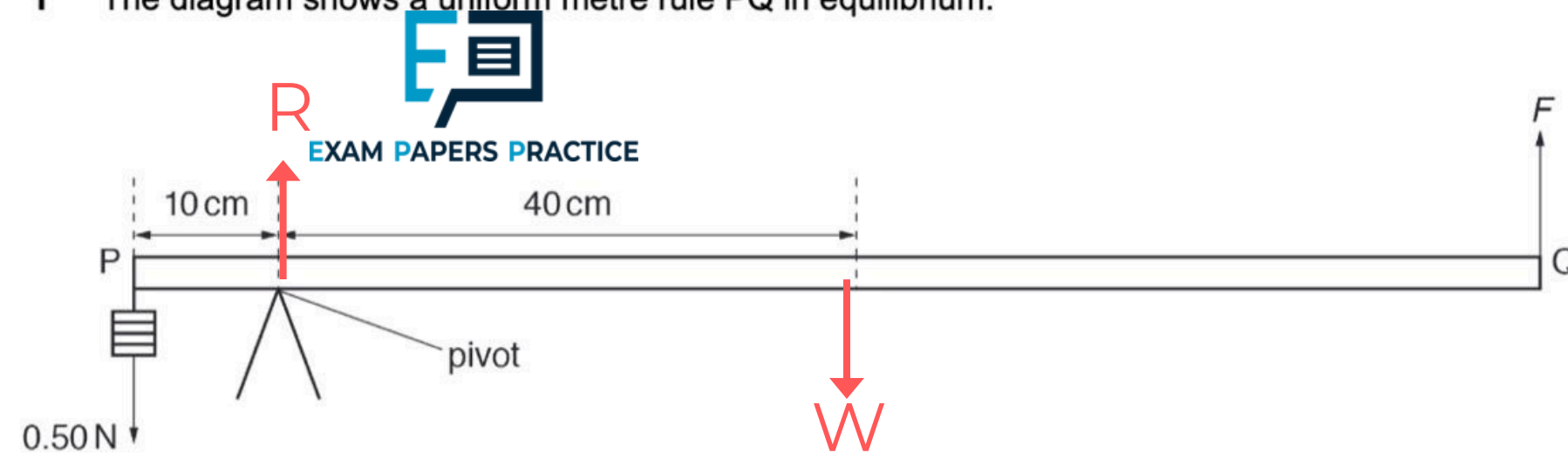

The distance PQ is 100 cm. The mass of the metre rule is 0.12 kg and its weight is W .

(a) On the diagram, draw and label:

1. an arrow to show the force W acting on PQ at the centre of mass
2. an arrow to show the force R acting on PQ at the pivot.

[2]

(b) By taking moments about the pivot, calculate F .

$$CW = ACW$$

$$(1.2 \times 0.4) = (0.5 \times 0.1) + 0.9F$$

$$0.43 = 0.9F$$

$$F = 0.47\text{N}$$

$$0.47\text{N}$$

$$F = \dots\dots\dots [4]$$

(c) Calculate R .

Upward force = Downward force

Downward force = $0.5\text{N} + 1.2\text{N} = 1.7\text{N}$

Upward force = $0.47\text{N} + R$

$R = 1.7\text{N} - 0.47\text{N} = 1.23\text{N}$

$$1.23\text{N}$$

$$R = \dots\dots\dots [2]$$