

Write your name here

Surname

Other names

Pearson
Edexcel GCSE

Centre Number

--	--	--	--	--	--

Candidate Number

--	--	--	--	--

Physics

Unit P3: Applications of Physics

Higher Tier

Friday 24 June 2016 – Morning

Time: 1 hour

Paper Reference

5PH3H/01

You must have:

Calculator, ruler

Total Marks

Instructions

- Use **black** ink or ball-point pen.
- **Fill in the boxes** at the top of this page with your name, centre number and candidate number.
- Answer **all** questions.
- Answer the questions in the spaces provided
– *there may be more space than you need.*

Information

- The total mark for this paper is 60.
- The marks for **each** question are shown in brackets
– *use this as a guide as to how much time to spend on each question.*
- Questions labelled with an **asterisk** (*) are ones where the quality of your written communication will be assessed
– *you should take particular care with your spelling, punctuation and grammar, as well as the clarity of expression, on these questions.*

Advice

- Read each question carefully before you start to answer it.
- Try to answer every question.
- Check your answers if you have time at the end.

Turn over ►

P46515A

©2016 Pearson Education Ltd.

1/1/1/1/1



PEARSON

FORMULAE

You may find the following formulae useful.

$$\text{energy} = \text{mass} \times (\text{speed of light})^2$$

$$E = mc^2$$

$$\text{intensity} = \frac{\text{power of incident radiation}}{\text{area}}$$

$$I = \frac{P}{A}$$

$$\text{power of lens} = \frac{1}{\text{focal length}}$$

The relationship between focal length, object and image distance

$$\frac{1}{f} = \frac{1}{u} + \frac{1}{v}$$

current = number of particles per second \times charge on each particle

$$I = Nq$$

kinetic energy = electronic charge \times accelerating potential difference

$$\text{KE} = \frac{1}{2} mv^2 = e \times V$$

$$\text{frequency} = \frac{1}{\text{time period}}$$

$$f = \frac{1}{T}$$

The relationship between temperature and volume for a gas

$$V_1 = \frac{V_2 T_1}{T_2}$$

The relationship between volume and pressure for a gas

$$V_1 P_1 = V_2 P_2$$

The relationship between the volume, pressure and temperature for a gas

$$\frac{P_1 V_1}{T_1} = \frac{P_2 V_2}{T_2}$$

DO NOT WRITE IN THIS AREA

DO NOT WRITE IN THIS AREA

DO NOT WRITE IN THIS AREA



DO NOT WRITE IN THIS AREA

DO NOT WRITE IN THIS AREA

DO NOT WRITE IN THIS AREA

BLANK PAGE

Questions begin on next page.



Answer ALL questions.

Some questions must be answered with a cross \boxtimes .
If you change your mind about an answer, put a line through the box \boxtimes and then mark your new answer with a cross \boxtimes .

Collisions and momentum

- 1 (a) Complete the sentence by putting a cross (\boxtimes) in the box next to your answer.

(1)

Momentum is conserved in collisions provided that

- A no crumpling of objects occurs
- B no energy is lost as heat or sound
- C no external forces act
- D no friction is involved

- (b) A student uses a horizontal air track to investigate collisions.

The air track blows air through a series of small holes.

Two small gliders, M_1 and M_2 , float on a cushion of air.

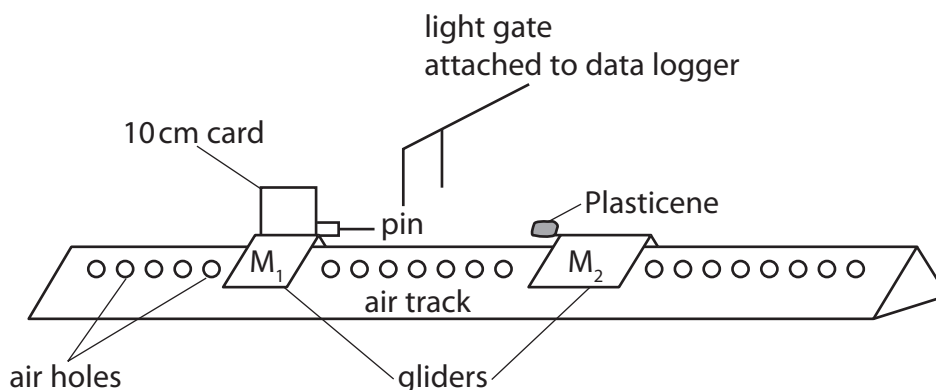

The student pushes the first glider M_1 towards glider M_2 , which is stationary.

As the glider M_1 goes through the light gate, its velocity is measured.

Glider M_1 hits and sticks to glider M_2 and they move off together.

The student takes the following measurements.

mass of glider M_1	0.21 kg
mass of glider M_2	0.21 kg
velocity measured by the light gate	0.47 m/s

DO NOT WRITE IN THIS AREA

DO NOT WRITE IN THIS AREA

DO NOT WRITE IN THIS AREA



(i) Show that the momentum of glider M_1 before the collision is about 0.10 kg m/s . (2)

(ii) The total momentum before the collision is equal to the total momentum after the collision.

Calculate the velocity of the two gliders combined after the collision. (3)

velocity after the collision = m/s

(iii) The total kinetic energy before collision = 0.023 J .

The total kinetic energy after collision = 0.012 J .

Discuss whether the collision is elastic or inelastic. (2)

.....

.....

.....

.....

(Total for Question 1 = 8 marks)

DO NOT WRITE IN THIS AREA

DO NOT WRITE IN THIS AREA

DO NOT WRITE IN THIS AREA



Radioactivity

- 2 (a) An electron has a charge of -1.6×10^{-19} C.

An alpha (α) particle is a helium nucleus.

A beta particle is a fast moving electron.

Complete the sentence by putting a cross (☒) in the box next to your answer.

(1)

The charge carried by an alpha particle is

- A -1.6×10^{-19} C
- B $+1.6 \times 10^{-19}$ C
- C -3.2×10^{-19} C
- D $+3.2 \times 10^{-19}$ C

- (b) (i) Explain why alpha (α) particles only travel a few centimetres in air.

(2)

.....

.....

.....

.....

- (ii) State why beta particles can travel further in air than alpha particles.

(1)

.....

.....

.....

DO NOT WRITE IN THIS AREA

DO NOT WRITE IN THIS AREA

DO NOT WRITE IN THIS AREA



(iii) The kinetic energy of an alpha particle is $8.1 \times 10^{-13} \text{ J}$.

The mass of the alpha particle is $6.6 \times 10^{-27} \text{ kg}$.

Calculate the speed of the alpha particle.

(3)

speed = m/s

(iv) State the speed of gamma rays emitted by an unstable nucleus.

(1)

(Total for Question 2 = 8 marks)

DO NOT WRITE IN THIS AREA

DO NOT WRITE IN THIS AREA

DO NOT WRITE IN THIS AREA



Gases and kinetic theory

- 3 A student uses this apparatus to investigate how the volume of air changes with pressure.

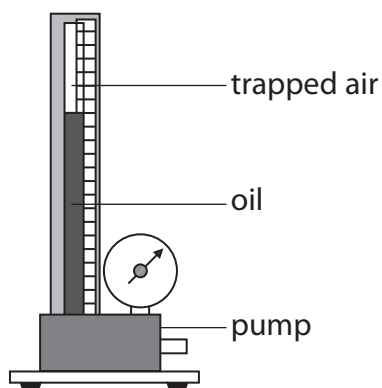

He obtains these results and starts to plot a graph.

Pressure / kPa	Volume, V / cm^3	$1/V$ / $1/\text{cm}^3$
190	14.9	0.067
168	16.6	0.060
156	18.1	0.055
139	20.7	0.048
119	23.7	0.042
95	30.1	0.033

DO NOT WRITE IN THIS AREA

DO NOT WRITE IN THIS AREA

DO NOT WRITE IN THIS AREA



(a) (i) The two sets of results not plotted on the graph are shaded in the table.

Complete the graph by plotting these results.

(2)

(ii) Draw a line of best fit.

(1)

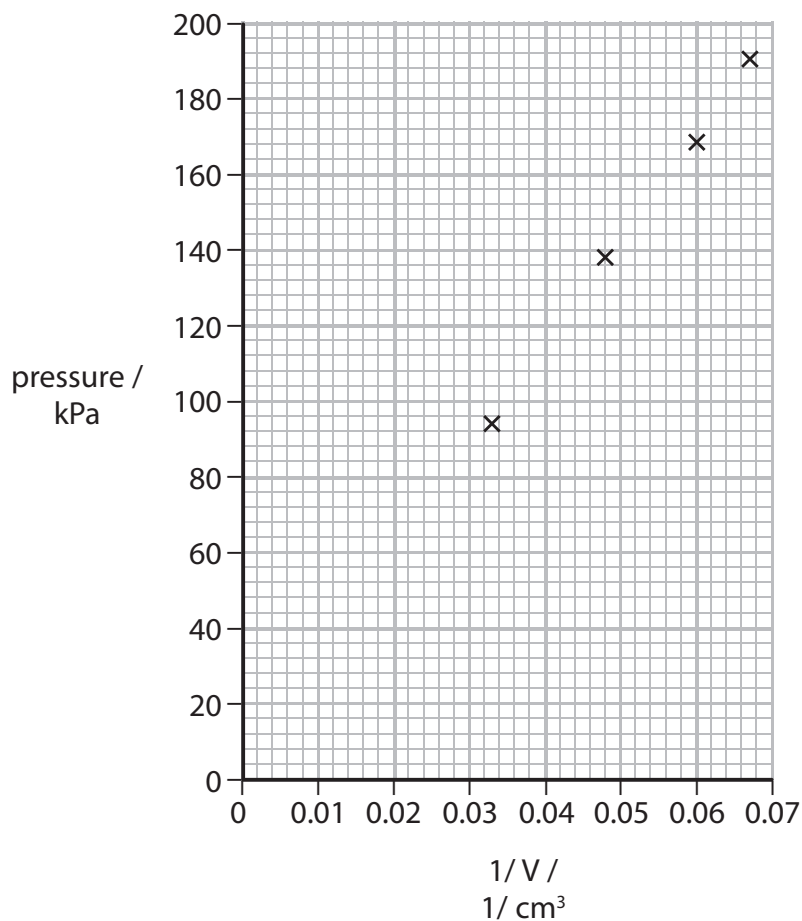

(iii) Describe the relationship shown by the graph.

(2)

.....

.....

.....

.....



(b) The diagram shows a bubble of air rising in the atmosphere.

The mass of the bubble of air remains constant.

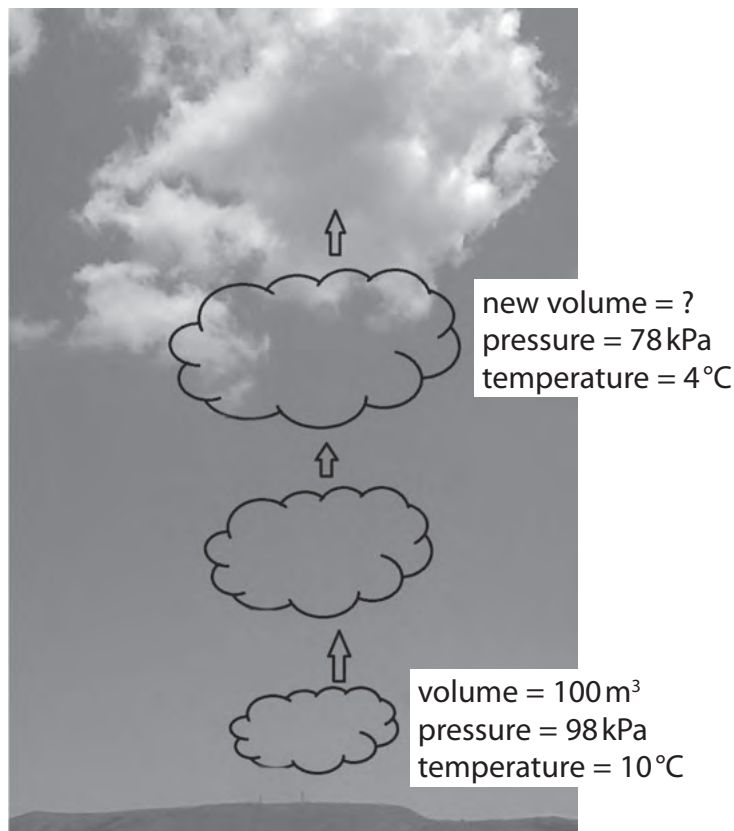

(i) State what 10°C is in kelvin.

(1)

..... K

(ii) Use the data in the diagram to calculate the volume of the air bubble when its pressure is 78 kPa.

(3)

volume = m³



(iii) Which of these statements is correct?

Put a cross (☒) in the box next to your answer.

(1)

As the bubble of air rises into the sky, the average kinetic energy of its molecules

- A increases
- B decreases
- C stays the same
- D cannot be determined from the data given

(Total for Question 3 = 10 marks)

DO NOT WRITE IN THIS AREA

DO NOT WRITE IN THIS AREA

DO NOT WRITE IN THIS AREA



P 4 6 5 1 5 A 0 1 1 2 0

Sight problems

4 Defects of vision can be corrected by changing the paths of light rays.

(a) Explain why light refracts towards the normal when it passes from air into glass or water.

(2)

(b) The diagram shows light from a distant object being brought to a focus on the retina of a normal eye.

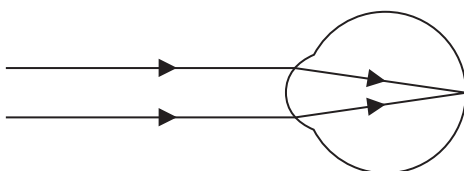

Complete the sentence by putting a cross (☒) in the box next to your answer.

(1)

Light is brought to a focus on the retina after refraction by the

- A cornea and iris
- B lens and cornea
- C lens and iris
- D pupil and iris

DO NOT WRITE IN THIS AREA

DO NOT WRITE IN THIS AREA

DO NOT WRITE IN THIS AREA



DO NOT WRITE IN THIS AREA

DO NOT WRITE IN THIS AREA

DO NOT WRITE IN THIS AREA

(c) This diagram shows light from a distant object being brought to a focus in front of the retina of an eye with a defect of vision.

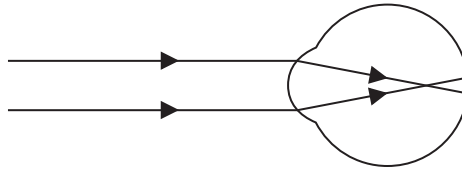

(i) State the name of this defect of vision.

(1)

(ii) Explain how this defect of vision can be corrected with a lens.

You may add to the diagram above or draw another diagram to help with your answer.

(2)

(iii) Describe how this defect of vision can be corrected using laser surgery.

(2)



P 4 6 5 1 5 A 0 1 3 2 0

(iv) The image shows a laser beam incident on an eye.



The power of the laser is 40 mW.

The beam covers an area of $1.8 \times 10^{-6} \text{ m}^2$.

Calculate the intensity of the laser beam.

(2)

intensity of laser beam = W/m²

(Total for Question 4 = 10 marks)

DO NOT WRITE IN THIS AREA

DO NOT WRITE IN THIS AREA

DO NOT WRITE IN THIS AREA



PET scanner

- 5 The diagram shows what happens when a positron and electron collide.

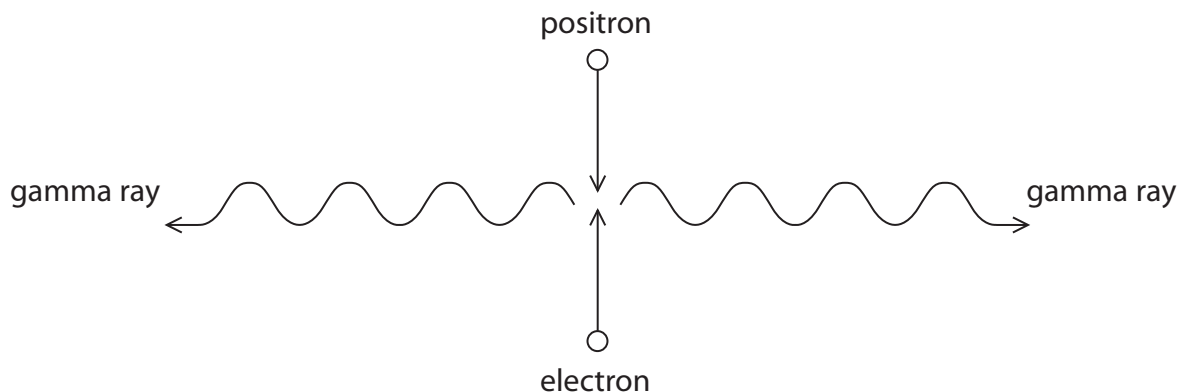

- (a) (i) What is the name given to this interaction between a positron and an electron?

Put a cross (☒) in the box next to your answer.

(1)

- A annihilation
- B beta decay
- C cosmic background radiation
- D ionisation

- (ii) A PET scanner uses positrons.

What does a PET scanner use to produce positrons?

Put a cross (☒) in the box next to your answer.

(1)

- A alpha particles
- B gamma cameras
- C positive ions
- D radioactive isotopes

DO NOT WRITE IN THIS AREA

DO NOT WRITE IN THIS AREA

DO NOT WRITE IN THIS AREA



P 4 6 5 1 5 A 0 1 5 2 0

(b) (i) Both the positron and electron have mass.

The gamma rays do not have any mass.

State what happens to the mass in a positron-electron interaction.

(1)

(ii) Calculate the energy of an electron of mass 9.1×10^{-31} kg.

The speed of light, $c = 3.0 \times 10^8$ m/s.

(2)

energy = J

(iii) Suggest a reason why PET scanners need to be located near a cyclotron.

(1)



DO NOT WRITE IN THIS AREA

DO NOT WRITE IN THIS AREA

DO NOT WRITE IN THIS AREA

*(c) A patient with a brain tumour is given a fluorine-18 injection.

The patient is then given a PET scan.

Explain the steps in the PET scan process used to locate the brain tumour.

You may draw a diagram if it helps your answer.

(6)

Area with horizontal dotted lines for writing the answer.

(Total for Question 5 = 12 marks)



X-rays

- 6 (a) The diagram shows the main parts of an X-ray tube.

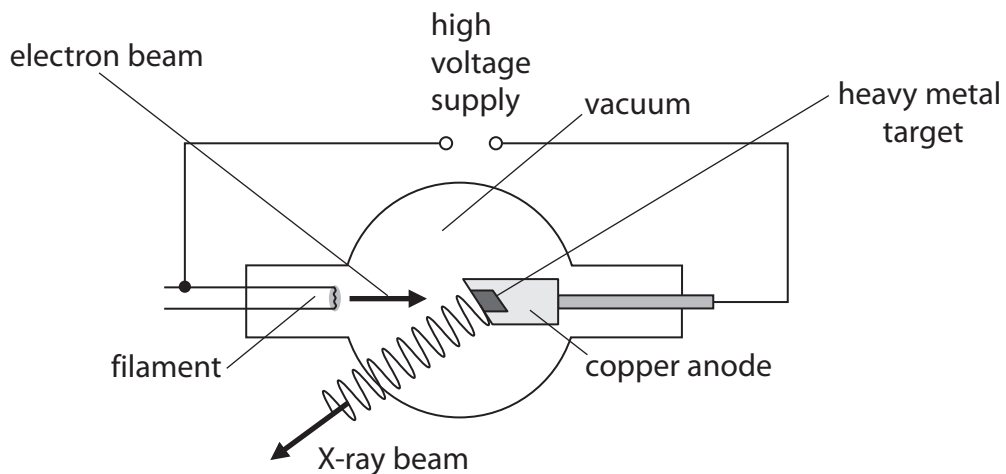

- (i) The electrons in the beam escape from a hot filament.

State the name of the process by which electrons escape from a hot filament.

(1)

- (ii) Explain why there must be a vacuum inside the X-ray tube.

(2)

DO NOT WRITE IN THIS AREA

DO NOT WRITE IN THIS AREA

DO NOT WRITE IN THIS AREA



(iii) 3.0×10^{17} electrons reach the target every second.

The charge on an electron is $1.6 \times 10^{-19}\text{C}$.

Calculate the current in the circuit.

(2)

current =A

(iv) The intensity, I , of X-rays varies with the distance, d , from the source of the X-rays.

Complete the sentence by putting a cross (☒) in the box next to your answer.

(1)

The relationship between I and d for a point source is

- A** I is inversely proportional to d
- B** I is proportional to d
- C** I is inversely proportional to d^2
- D** I is proportional to d^2

DO NOT WRITE IN THIS AREA

DO NOT WRITE IN THIS AREA

DO NOT WRITE IN THIS AREA



P 4 6 5 1 5 A 0 1 9 2 0

